

SERVICE & OPERATING MANUAL

Original Instructions

Certified Quality



Quality System
ISO 9001 Certified



Environmental Management System
ISO 14001 Certified



Warren Rupp, Inc.
A Unit of IDEX Corporation
800 N. Main St.,
Mansfield, Ohio 44902 USA
Telephone (419) 524.8388
Fax (419) 522.7867
SANDPIPERPUMP.COM



© Copyright 2014 Warren Rupp, Inc.
All rights reserved

Model S1F

Non-Metallic Design Level 3

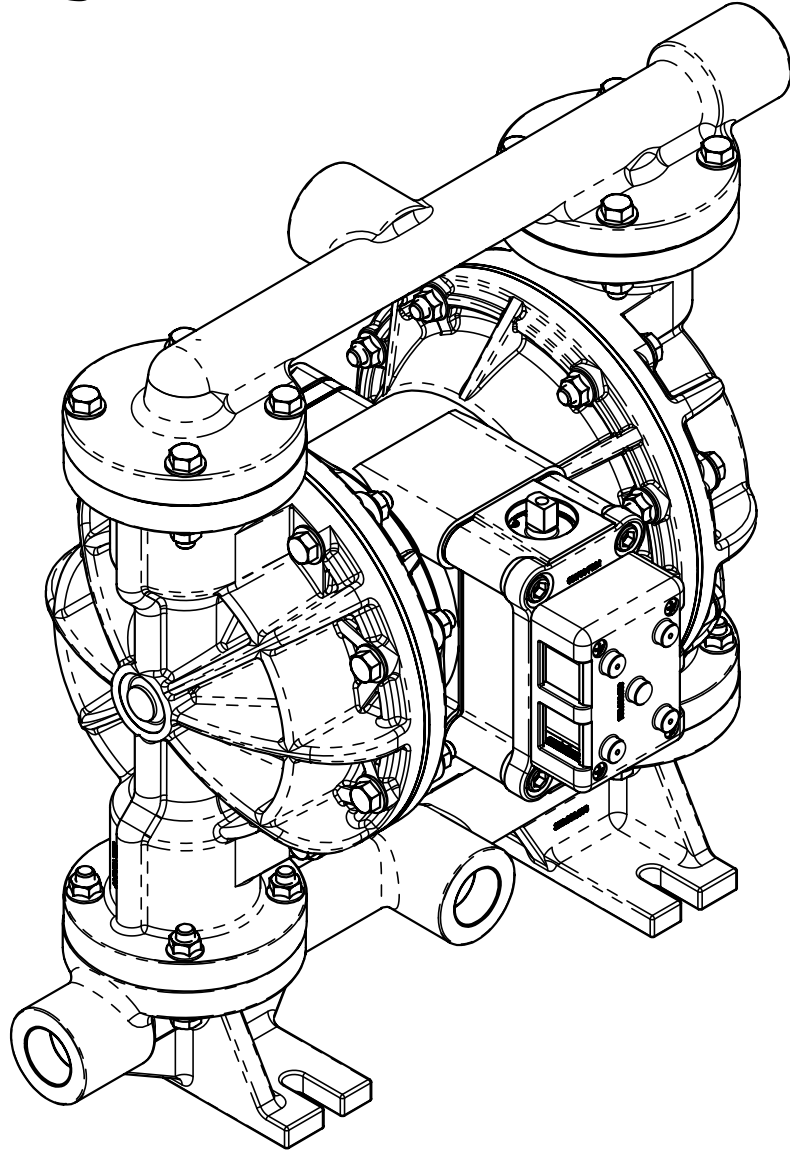

1: PUMP SPECS

2: INSTAL & OP

3: EXP VIEW

4: AIR END

5: WET END

6: OPTIONAL

7: WARRANTY

SANDPIPER[®]
A WARREN RUPP, INC. BRAND

SANDPIPERPUMP.COM

Safety Information

IMPORTANT



Read the safety warnings and instructions in this manual before pump installation and start-up. Failure to comply with the recommendations stated in this manual could damage the pump and void factory warranty.



When the pump is used for materials that tend to settle out or solidify, the pump should be flushed after each use to prevent damage. In freezing temperatures the pump should be completely drained between uses.

CAUTION



Before pump operation, inspect all fasteners for loosening caused by gasket creep. Retighten loose fasteners to prevent leakage. Follow recommended torques stated in this manual.



Nonmetallic pumps and plastic components are not UV stabilized. Ultraviolet radiation can damage these parts and negatively affect material properties. Do not expose to UV light for extended periods of time.



WARNING
Pump not designed, tested or certified to be powered by compressed natural gas. Powering the pump with natural gas will void the warranty.

WARNING



When used for toxic or aggressive fluids, the pump should always be flushed clean prior to disassembly.



Before maintenance or repair, shut off the compressed air line, bleed the pressure, and disconnect the air line from the pump. Be certain that approved eye protection and protective clothing are worn at all times. Failure to follow these recommendations may result in serious injury or death.



Airborne particles and loud noise hazards. Wear eye and ear protection.



In the event of diaphragm rupture, pumped material may enter the air end of the pump, and be discharged into the atmosphere. If pumping a product that is hazardous or toxic, the air exhaust must be piped to an appropriate area for safe containment.



Take action to prevent static sparking. Fire or explosion can result, especially when handling flammable liquids. The pump, piping, valves, containers and other miscellaneous equipment must be properly grounded.



This pump is pressurized internally with air pressure during operation. Make certain that all fasteners are in good condition and are reinstalled properly during reassembly.



Use safe practices when lifting

Grounding the Pump

To be fully groundable, the pumps must be ATEX Compliant. Refer to the nomenclature page for ordering information.

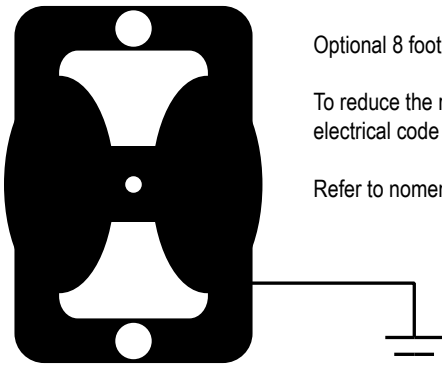

Optional 8 foot long (244 centimeters) Ground Strap is available for easy ground connection.

To reduce the risk of static electrical sparking, this pump must be grounded. Check the local electrical code for detailed grounding instruction and the type of equipment required.

Refer to nomenclature page for ordering information.

WARNING



Take action to prevent static sparking. Fire or explosion can result, especially when handling flammable liquids. The pump, piping, valves, containers or other miscellaneous equipment must be grounded.

Table of Contents

SECTION 1: PUMP SPECIFICATIONS.....1

- Explanation of Nomenclature
- Performance
- Materials
- Dimensional Drawings

SECTION 2: INSTALLATION & OPERATION.....5

- Principle of Pump Operation
- Recommended Installation Guide
- Troubleshooting Guide

SECTION 3: EXPLODED VIEW.....8

- Composite Repair Parts Drawing
- Composite Repair Parts List
- Material Codes
- Option For Virgin PTFE & TPE Equipped Pumps Drawing

SECTION 4: AIR END.....13

- Air Distribution Valve Assembly
- Air Valve with Stroke Indicator Assembly
- Pilot Valve Assembly
- Intermediate Assembly

SECTION 5: WET END17

- Diaphragm Drawings
- Diaphragm Servicing

SECTION 6: OPTIONAL CONFIGURATIONS....19

- Solenoid Shifted Air Valve
- Dual Port
- Electronic Leak Detector Installation Instructions

SECTION 7: WARRANTY & CERTIFICATES22

- Warranty
- CE Declaration of Conformity - Machinery
- ATEX Declaration of Conformity
- ATEX Summary of Markings

1: PUMP SPECS

2: INSTAL & OP

3: EXP VIEW

4: AIR END

5: WET END

6: OPTIONAL

7: WARRANTY

Explanation of Pump Nomenclature

Your Model #: **S**
(fill in from pump nameplate)

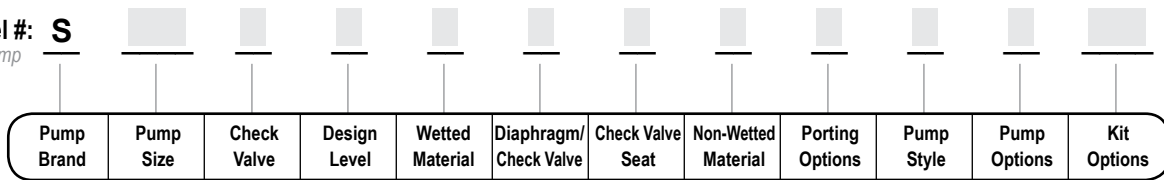

Model #: **S XX X X X X X X X X X XX**

Pump Brand
S SANDPIPER®

Pump Size
1F 1" Full Flow

Check Valve Type
B Ball

Design Level
3 Design Level

Wetted Material
K PVDF

- C Conductive Polypropylene
- V Conductive PVDF

Diaphragm/Check Valve Materials

- 1 Santoprene/Santoprene
- 2 PTFE Santoprene Backup/PTFE
- 3 PTFE Pumping, PTFE-Santoprene Backup Driver/PTFE
- 4 Santoprene Pumping/Santoprene
- B Nitrile/Nitrile
- G PTFE-Neoprene Backup/PTFE
- M Santoprene/PTFE
- N Neoprene/Neoprene
- V FKM/FKM
- Y PTFE Pumping/One-Piece Bonded Driver/PTFE
- Z One-Piece Bonded/PTFE

Check Valve Seat
K PVDF
P Polypropylene

Non-Wetted Material Options

- P Polypropylene
- 1 40% Glass Filled Polypropylene with PTFE hardware
- C Conductive Polypropylene

Porting Options

- N NPT Thread
- U Universal (Fits ANSI and DIN)
- 7 Dual Porting (ANSI)
- 8 Top Dual Porting (ANSI)
- 9 Bottom Dual Porting (ANSI)

Pump Style

- D With Electronic Leak Detection (110 V)
- E With Electronic Leak Detection (220V)
- I Inline Porting NPT Threads
- M With Mechanical Leak Detection
- S Standard
- V With Visual Leak Detection

Pump Options

- 0 None
- 1 Sound Dampening Muffler
- 2 Mesh Muffler
- 3 Expanded Clearance Air Valve w/Integral Muffler
- 4 Expanded Clearance Air Valve w/Sound Dampening Muffler
- 5 Expanded Clearance Air Valve w/Mesh Muffler
- 6 Metal Muffler
- 7 Metal Muffler with Grounding Cable

Kit Options

- 00. None
 - P0. 10.30VDC Pulse Output Kit
 - P1. Intrinsically-Safe 5.30VDC, 110/120VAC 220/240 VAC Pulse Output Kit
 - P2. 110/120 or 220/240VAC Pulse Output Kit
 - E0. Solenoid Kit with 24VDC Coil
 - E1. Solenoid Kit with 24VDC Explosion-Proof Coil
 - E2. Solenoid Kit with 24VAC/12VDC Coil
 - E3. Solenoid Kit with 12VDC Explosion-Proof Coil
 - E4. Solenoid Kit with 110VAC Coil
 - E5. Solenoid Kit with 110VAC Explosion-Proof Coil
 - E6. Solenoid Kit with 220VAC Coil
 - E7. Solenoid Kit with 220VAC Explosion-Proof Coil
 - E8. Solenoid Kit with 110VAC, 50 Hz Explosion-Proof Coil
 - E9. Solenoid Kit with 230VAC, 50 Hz Explosion-Proof Coil
 - SP. Stroke Indicator Pins
-
- A1. Solenoid Kit with 12 VDC ATEX Compliant Coil
 - A2. Solenoid Kit with 24 VDC ATEX Compliant Coil
 - A3. Solenoid Kit with 110/120 VAC 50/60 Hz ATEX Compliant Coil
 - A4. Solenoid Kit with 220/240 VAC 50/60 Hz ATEX Compliant Coil

Your Serial #: (fill in from pump nameplate) _____

ATEX Detail

- (1) II 1G c T5
II 3/1 G c T5
II 1D c T100°C
I M1 c
I M2 c

Note: Pumps are only ATEX compliant when ordered with wetted material option C or V, non-wetted material option C, pump option 0, 6 or 7, and kit option 0.

- (3) II 2G EEx m c II T5
II 3/2 2G EEx m c II T5
II 2D c IP65 T100°C

Note: Pumps ordered with the options listed in (1) to the left are ATEX compliant when ordered with kit option A1, A2, A3, or A4. Compressed Air Temperature Range: Maximum Ambient Temperature to plus 50°C.
***Note:** See Special Conditions For Safe Use.

- (2) II 2G Ex ia c IIC T5
II 3/2 G Ex ia c IIC T5
II 2D Ex c ia 20 IP67 T100°C

Note: Pumps ordered with the options listed in (1) to the left are ATEX compliant when ordered with kit option P1.

- (4) IEC EEx m T4



Note: Pump models equipped with these explosion-proof solenoid kit options E1, E3, E5, E7, E8 or E9, are certified and approved by the above agencies. They are NOT ATEX compliant.

Performance

S1F NON-METALLIC

SUCTION/DISCHARGE PORT SIZE

- 1" ANSI Flange or
PN10 25mm DIN Flange

CAPACITY

- 0 to 53 gallons per minute
(0 to 200 liters per minute)

AIR DISTRIBUTION VALVE

- No-lube, no-stall design

SOLIDS-HANDLING

- Up to .25 in. (6mm)

HEADS UP TO

- 100 psi or 231 ft. of water
(7 bar or 70 meters)

DISPLACEMENT/STROKE

- .19 Gallon / .72 liter

MAXIMUM OPERATING PRESSURE

- 100 psi (7 bar)

SHIPPING WEIGHT

- Polypropylene 42 lbs. (19kg)
- PVDF 54 lbs. (24kg)

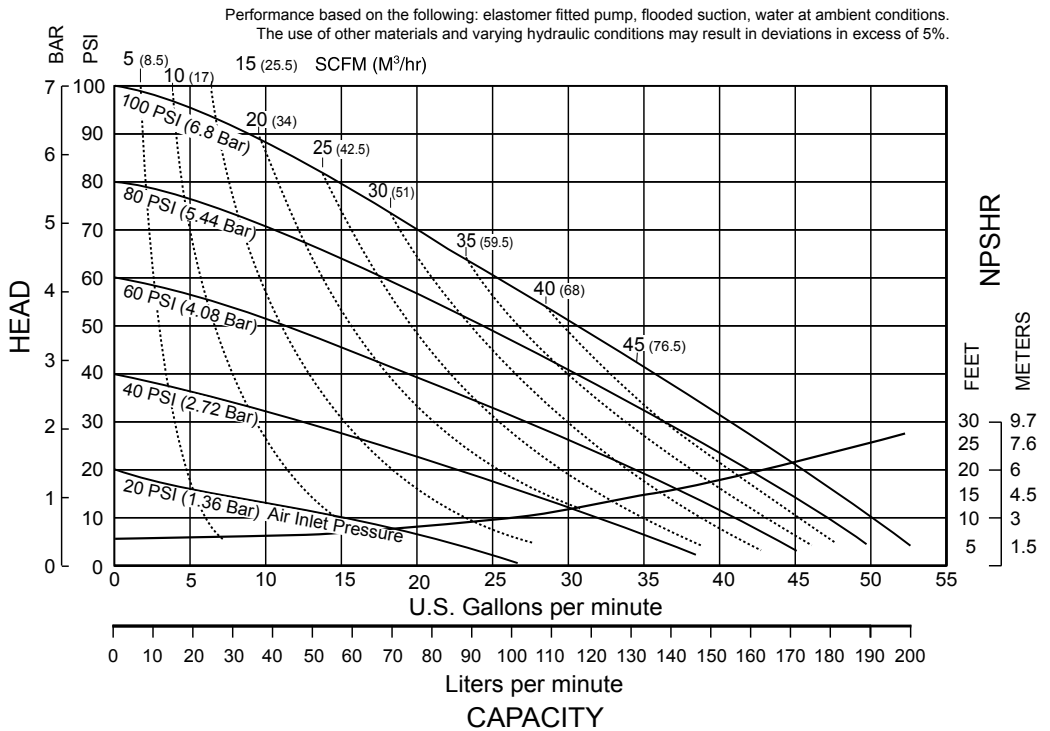

1: PUMP SPECS

Materials

| Material Profile: | Operating Temperatures: | | 180°F 82°C | 32°F 0°C |
|--|-------------------------|----------------|----------------|----------------|
| | Max. | Min. | | |
| CAUTION! Operating temperature limitations are as follows: | | | | |
| Conductive Acetal: Tough, impact resistant, ductile. Good abrasion resistance and low friction surface. Generally inert, with good chemical resistance except for strong acids and oxidizing agents. | 190°F 88°C | -20°F -29°C | | |
| EPDM: Shows very good water and chemical resistance. Has poor resistance to oils and solvents, but is fair in ketones and alcohols. | 280°F 138°C | -40°F -40°C | | |
| FKM: (Fluorocarbon) Shows good resistance to a wide range of oils and solvents; especially all aliphatic, aromatic and halogenated hydrocarbons, acids, animal and vegetable oils. Hot water or hot aqueous solutions (over 70°F(21°C)) will attack FKM. | 350°F 177°C | -40°F -40°C | | |
| Hytrel®: Good on acids, bases, amines and glycols at room temperatures only. | 220°F 104°C | -20°F -29°C | | |
| Neoprene: All purpose. Resistance to vegetable oils. Generally not affected by moderate chemicals, fats, greases and many oils and solvents. Generally attacked by strong oxidizing acids, ketones, esters and nitro hydrocarbons and chlorinated aromatic hydrocarbons. | 200°F 93°C | -10°F -23°C | | |
| Nitrile: General purpose, oil-resistant. Shows good solvent, oil, water and hydraulic fluid resistance. Should not be used with highly polar solvents like acetone and MEK, ozone, chlorinated hydrocarbons and nitro hydrocarbons. | 190°F 88°C | -10°F -23°C | | |
| Nylon: 6/6 High strength and toughness over a wide temperature range. Moderate to good resistance to fuels, oils and chemicals. | 180°F 82°C | 32°F 0°C | | |
| Polypropylene: A thermoplastic polymer. Moderate tensile and flex strength. Resists strong acids and alkali. Attacked by chlorine, fuming nitric acid and other strong oxidizing agents. | | | 180°F 82°C | 32°F 0°C |
| PVDF: (Polyvinylidene Fluoride) A durable fluoroplastic with excellent chemical resistance. Excellent for UV applications. High tensile strength and impact resistance. | | | 250°F 121°C | 0°F -18°C |
| Santoprene®: Injection molded thermoplastic elastomer with no fabric layer. Long mechanical flex life. Excellent abrasion resistance. | | | 275°F 135°C | -40°F -40°C |
| UHMW PE: A thermoplastic that is highly resistant to a broad range of chemicals. Exhibits outstanding abrasion and impact resistance, along with environmental stress-cracking resistance. | | | 180°F 82°C | -35°F -37°C |
| Urethane: Shows good resistance to abrasives. Has poor resistance to most solvents and oils. | | | 150°F 66°C | 32°F 0°C |
| Virgin PTFE: (PFA/TFE) Chemically inert, virtually impervious. Very few chemicals are known to chemically react with PTFE; molten alkali metals, turbulent liquid or gaseous fluorine and a few fluoro-chemicals such as chlorine trifluoride or oxygen difluoride which readily liberate free fluorine at elevated temperatures. | | | 220°F 104°C | -35°F -37°C |
| <i>Maximum and Minimum Temperatures are the limits for which these materials can be operated. Temperatures coupled with pressure affect the longevity of diaphragm pump components. Maximum life should not be expected at the extreme limits of the temperature ranges.</i> | | | | |
| Metals: | | | | |
| Alloy C: Equal to ASTM494 CW-12M-1 specification for nickel and nickel alloy. | | | | |
| Stainless Steel: Equal to or exceeding ASTM specification A743 CF-8M for corrosion resistant iron chromium, iron chromium nickel and nickel based alloy castings for general applications. Commonly referred to as 316 Stainless Steel in the pump industry. | | | | |

For specific applications, always consult the Chemical Resistance Chart.

- Ambient temperature range:** -20°C to +40°C
Process temperature range: -20°C to +80°C for models rated as category 1 equipment
-20°C to +100°C for models rated as category 2 equipment

In addition, the ambient temperature range and the process temperature range do not exceed the operating temperature range of the applied non-metallic parts as listed in the manuals of the pumps.

Dimensional Drawings

1: PUMP SPECS

S1F Non-Metallic Inline Ported Option- Polypropylene Wet End Models ONLY

Dimensions in inches (metric dimensions in brackets). Dimensional Tolerance .125" (3mm).

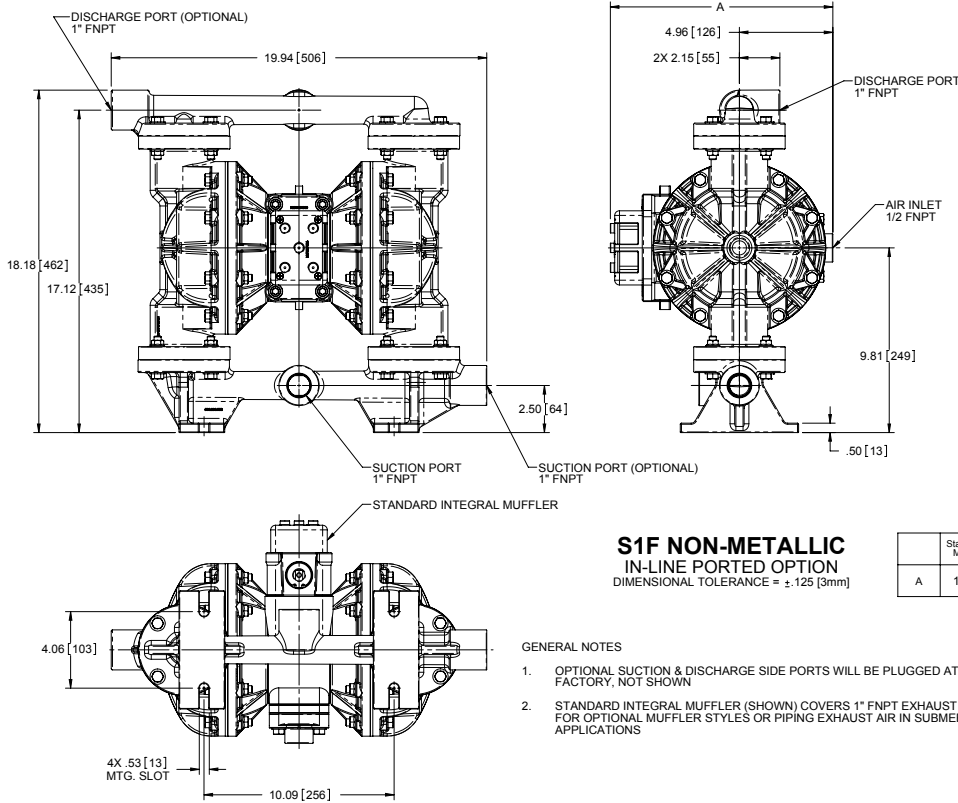

S1F Non-Metallic Side Ported Options

Dimensions in inches (metric dimensions in brackets). Dimensional Tolerance .125" (3mm).

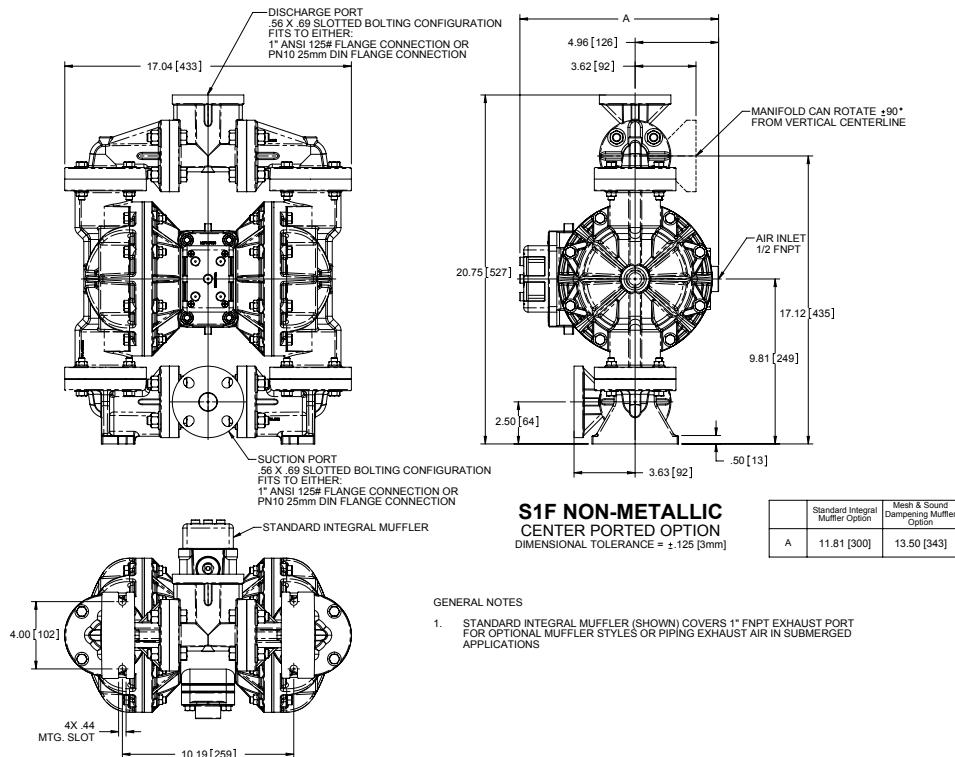

Dimensional Drawings

S1F Non-Metallic with Spill Containment

Dimensions in Inches. Dimensional tolerance: $\pm 1/8"$

1: PUMP SPECS

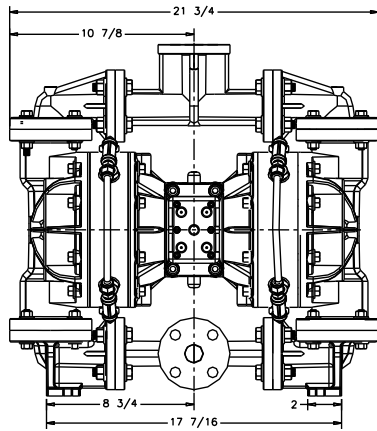

FRONT VIEW

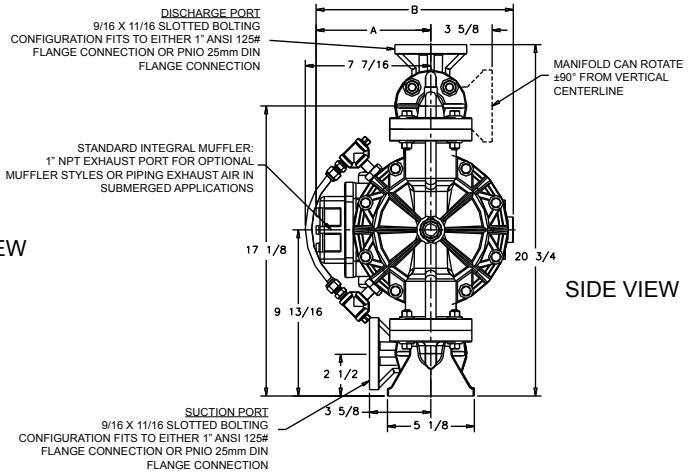

SIDE VIEW

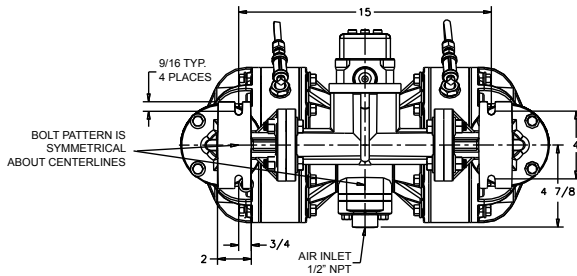

BOTTOM VIEW

| DIMENSION | A | B |
|-------------------------|---------|---------|
| Standard Pump | 5 5/8" | 10 1/4" |
| Pulse Output Kit | 5 5/8" | 10 1/4" |
| Mesh Muffler | 8 9/16" | 11 1/8" |
| Sound Dampening Muffler | 8 9/16" | 11 1/8" |

S1F Non-Metallic with Spill Containment (Metric)

Dimensions in Millimeters. Dimensional tolerance: $\pm 3\text{mm}$

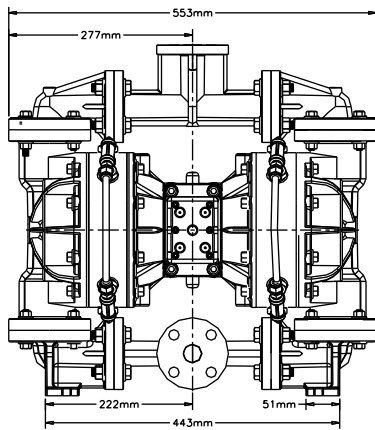

FRONT VIEW

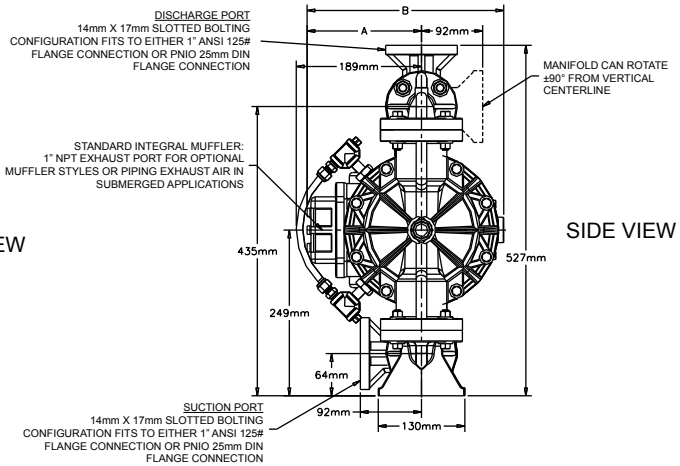

SIDE VIEW

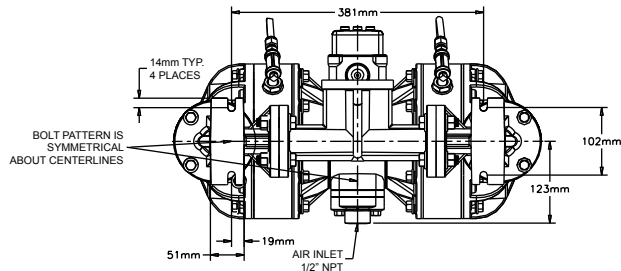

BOTTOM VIEW

| DIMENSION | A | B |
|-------------------------|-------|-------|
| Standard Pump | 143mm | 260mm |
| Pulse Output Kit | 143mm | 260mm |
| Mesh Muffler | 167mm | 283mm |
| Sound Dampening Muffler | 167mm | 283mm |

Principle of Pump Operation

2: INSTAL & OP

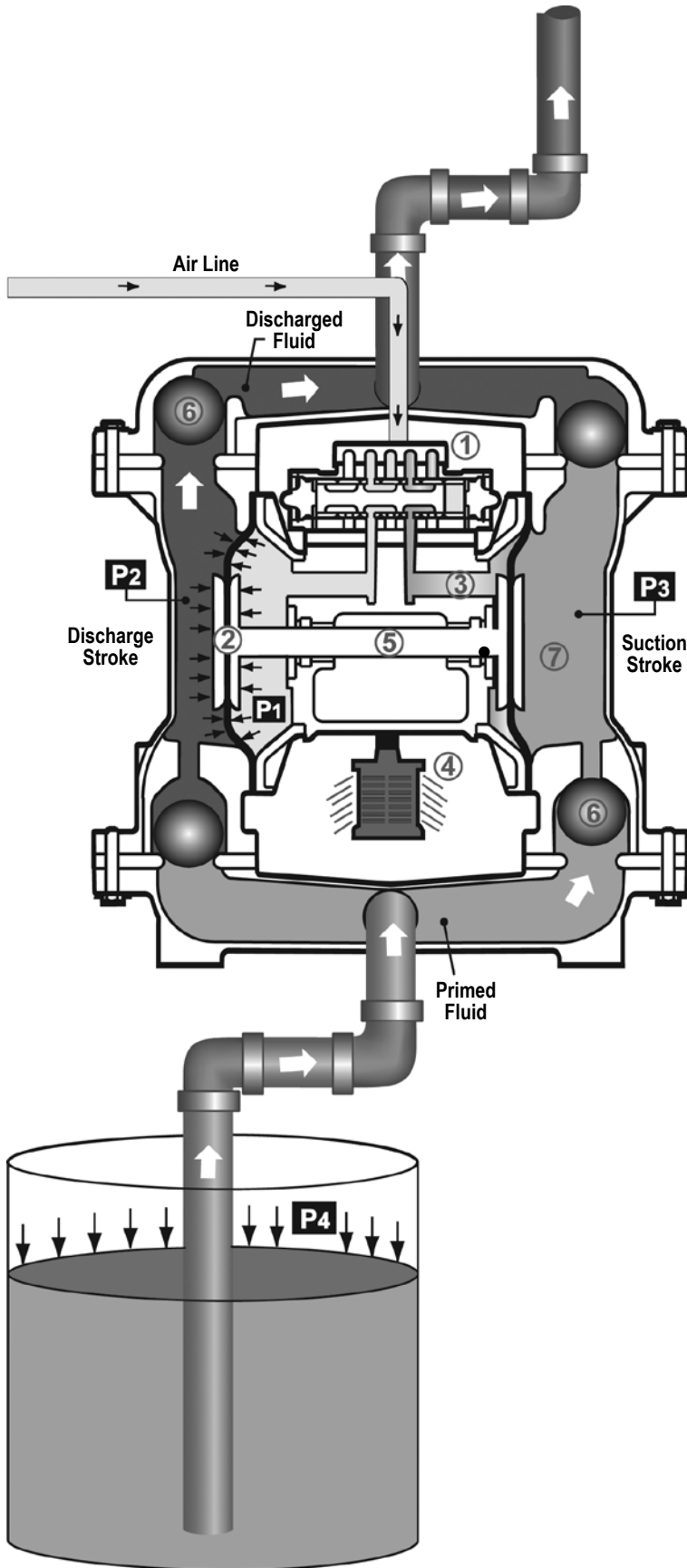

Air-Operated Double Diaphragm (AODD) pumps are powered by compressed air or nitrogen.

The main directional (air) control valve ① distributes compressed air to an air chamber, exerting uniform pressure over the inner surface of the diaphragm ②. At the same time, the exhausting air ③ from behind the opposite diaphragm is directed through the air valve assembly(s) to an exhaust port ④.

As inner chamber pressure (P1) exceeds liquid chamber pressure (P2), the rod ⑤ connected diaphragms shift together creating discharge on one side and suction on the opposite side. The discharged and primed liquid's directions are controlled by the check valves (ball or flap)⑥ orientation.

The pump primes as a result of the suction stroke. The suction stroke lowers the chamber pressure (P3) increasing the chamber volume. This results in a pressure differential necessary for atmospheric pressure (P4) to push the fluid through the suction piping and across the suction side check valve and into the outer fluid chamber ⑦.

Suction (side) stroking also initiates the reciprocating (shifting, stroking or cycling) action of the pump. The suction diaphragm's movement is mechanically pulled through its stroke. The diaphragm's inner plate makes contact with an actuator plunger aligned to shift the pilot signaling valve. Once actuated, the pilot valve sends a pressure signal to the opposite end of the main directional air valve, redirecting the compressed air to the opposite inner chamber.

SUBMERGED ILLUSTRATION

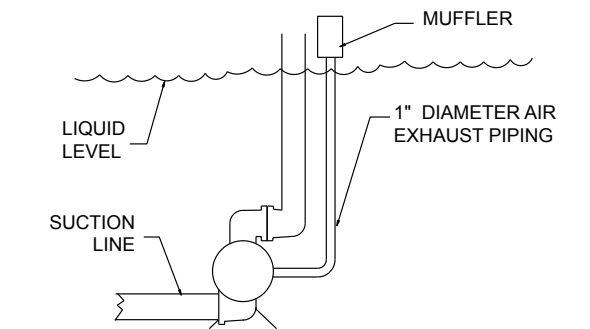

Pump can be submerged if the pump materials of construction are compatible with the liquid being pumped. The air exhaust must be piped above the liquid level. When the pumped product source is at a higher level than the pump (flooded suction condition), pipe the exhaust higher than the product source to prevent siphoning spills.

Recommended Installation Guide

Available Accessories:

1. Surge Suppressor
2. Filter/Regulator
3. Air Dryer

Note: Surge Suppressor and Piping must be supported after the flexible connection

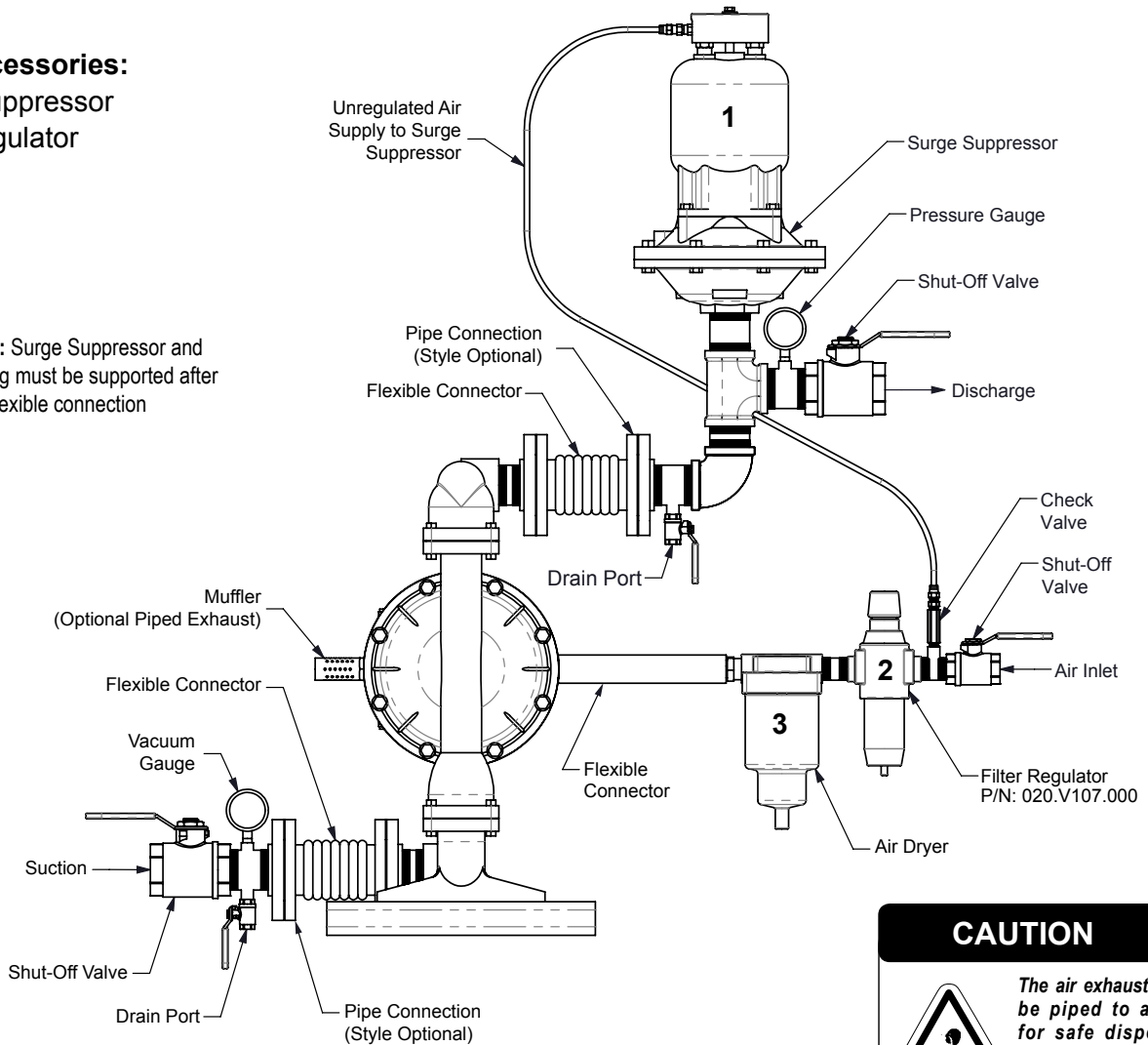

CAUTION

The air exhaust should be piped to an area for safe disposition of the product being pumped, in the event of a diaphragm failure.

Installation And Start-Up

Locate the pump as close to the product being pumped as possible. Keep the suction line length and number of fittings to a minimum. Do not reduce the suction line diameter.

Air Supply

Connect the pump air inlet to an air supply with sufficient capacity and pressure to achieve desired performance. A pressure regulating valve should be installed to insure air supply pressure does not exceed recommended limits.

Air Valve Lubrication

The air distribution system is designed to operate **WITHOUT** lubrication. This is the standard mode of operation. If lubrication is desired, install an air line lubricator set to deliver one drop of SAE 10 non-detergent oil for every 20 SCFM (9.4 liters/sec.) of air the pump consumes. Consult the Performance Curve to determine air consumption.

Air Line Moisture

Water in the compressed air supply may cause icing or freezing of the exhaust air, causing the pump to cycle erratically or stop operating. Water in the air supply can be reduced by using a point-of-use air dryer.

Air Inlet And Priming

To start the pump, slightly open the air shut-off valve. After the pump primes, the air valve can be opened to increase air flow as desired. If opening the valve increases cycling rate, but does not increase the rate of flow, cavitation has occurred. The valve should be closed slightly to obtain the most efficient air flow to pump flow ratio.

Troubleshooting Guide

2: INSTAL & OP

| Symptom: | Potential Cause(s): | Recommendation(s): |
|---|---|--|
| Pump Cycles Once | Deadhead (system pressure meets or exceeds air supply pressure). | Increase the inlet air pressure to the pump. Pump is designed for 1:1 pressure ratio at zero flow. (Does not apply to high pressure 2:1 units). |
| | Air valve or intermediate gaskets installed incorrectly. | Install gaskets with holes properly aligned. |
| | Bent or missing actuator plunger. | Remove pilot valve and inspect actuator plungers. |
| Pump Will Not Operate / Cycle | Pump is over lubricated. | Set lubricator on lowest possible setting or remove. Units are designed for lube free operation. |
| | Lack of air (line size, PSI, CFM). | Check the air line size and length, compressor capacity (HP vs. CFM required). |
| | Check air distribution system. | Disassemble and inspect main air distribution valve, pilot valve and pilot valve actuators. |
| | Discharge line is blocked or clogged manifolds. | Check for inadvertently closed discharge line valves. Clean discharge manifolds/piping. |
| | Deadhead (system pressure meets or exceeds air supply pressure). | Increase the inlet air pressure to the pump. Pump is designed for 1:1 pressure ratio at zero flow. (Does not apply to high pressure 2:1 units). |
| | Blocked air exhaust muffler. | Remove muffler screen, clean or de-ice, and re-install. |
| | Pumped fluid in air exhaust muffler. | Disassemble pump chambers. Inspect for diaphragm rupture or loose diaphragm plate assembly. |
| | Pump chamber is blocked. | Disassemble and inspect wetted chambers. Remove or flush any obstructions. |
| Pump Cycles and Will Not Prime or No Flow | Cavitation on suction side. | Check suction condition (move pump closer to product). |
| | Check valve obstructed. Valve ball(s) not seating properly or sticking. | Disassemble the wet end of the pump and manually dislodge obstruction in the check valve pocket. Clean out around valve ball cage and valve seat area. Replace valve ball or valve seat if damaged. Use heavier valve ball material. |
| | Valve ball(s) missing (pushed into chamber or manifold). | Worn valve ball or valve seat. Worn fingers in valve ball cage (replace part). Check Chemical Resistance Guide for compatibility. |
| | Valve ball(s) / seat(s) damaged or attacked by product. | Check Chemical Resistance Guide for compatibility. |
| | Check valve and/or seat is worn or needs adjusting. | Inspect check valves and seats for wear and proper setting. Replace if necessary. |
| | Suction line is blocked. | Remove or flush obstruction. Check and clear all suction screens or strainers. |
| | Excessive suction lift. | For lifts exceeding 20' of liquid, filling the chambers with liquid will prime the pump in most cases. |
| | Suction side air leakage or air in product. | Visually inspect all suction-side gaskets and pipe connections. |
| Pump Cycles Running Sluggish / Stalling, Flow Unsatisfactory | Pumped fluid in air exhaust muffler. | Disassemble pump chambers. Inspect for diaphragm rupture or loose diaphragm plate assembly. |
| | Over lubrication. | Set lubricator on lowest possible setting or remove. Units are designed for lube free operation. |
| | Icing. | Remove muffler screen, de-ice, and re-install. Install a point of use air drier. |
| | Clogged manifolds. | Clean manifolds to allow proper air flow. |
| | Deadhead (system pressure meets or exceeds air supply pressure). | Increase the inlet air pressure to the pump. Pump is designed for 1:1 pressure ratio at zero flow. (Does not apply to high pressure 2:1 units). |
| | Cavitation on suction side. | Check suction (move pump closer to product). |
| | Lack of air (line size, PSI, CFM). | Check the air line size, length, compressor capacity. |
| | Excessive suction lift. | For lifts exceeding 20' of liquid, filling the chambers with liquid will prime the pump in most cases. |
| | Air supply pressure or volume exceeds system hd. | Decrease inlet air (press. and vol.) to the pump. Pump is cavitating the fluid by fast cycling. |
| | Undersized suction line. | Meet or exceed pump connections. |
| | Restrictive or undersized air line. | Install a larger air line and connection. |
| | Suction side air leakage or air in product. | Visually inspect all suction-side gaskets and pipe connections. |
| | Suction line is blocked. | Remove or flush obstruction. Check and clear all suction screens or strainers. |
| | Pumped fluid in air exhaust muffler. | Disassemble pump chambers. Inspect for diaphragm rupture or loose diaphragm plate assembly. |
| | Product Leaking Through Exhaust | Check valve obstructed. |
| Check valve and/or seat is worn or needs adjusting. | | Inspect check valves and seats for wear and proper setting. Replace if necessary. |
| Entrained air or vapor lock in chamber(s). | | Purge chambers through tapped chamber vent plugs. Purging the chambers of air can be dangerous. |
| Premature Diaphragm Failure | Diaphragm failure, or diaphragm plates loose. | Replace diaphragms, check for damage and ensure diaphragm plates are tight. |
| | Diaphragm stretched around center hole or bolt holes. | Check for excessive inlet pressure or air pressure. Consult Chemical Resistance Chart for compatibility with products, cleaners, temperature limitations and lubrication. |
| | Cavitation. | Enlarge pipe diameter on suction side of pump. |
| | Excessive flooded suction pressure. | Move pump closer to product. Raise pump/place pump on top of tank to reduce inlet pressure. Install Back pressure device (Tech bulletin 41r). Add accumulation tank or pulsation dampener. |
| Unbalanced Cycling | Misapplication (chemical/physical incompatibility). | Consult Chemical Resistance Chart for compatibility with products, cleaners, temperature limitations and lubrication. |
| | Incorrect diaphragm plates or plates on backwards, installed incorrectly or worn. | Check Operating Manual to check for correct part and installation. Ensure outer plates have not been worn to a sharp edge. |
| | Excessive suction lift. | For lifts exceeding 20' of liquid, filling the chambers with liquid will prime the pump in most cases. |
| | Undersized suction line. | Meet or exceed pump connections. |
| | Pumped fluid in air exhaust muffler. | Disassemble pump chambers. Inspect for diaphragm rupture or loose diaphragm plate assembly. |
| | Suction side air leakage or air in product. | Visually inspect all suction-side gaskets and pipe connections. |
| | Check valve obstructed. | Disassemble the wet end of the pump and manually dislodge obstruction in the check valve pocket. |
| Check valve and/or seat is worn or needs adjusting. | Inspect check valves and seats for wear and proper setting. Replace if necessary. | |
| Unbalanced Cycling | Entrained air or vapor lock in chamber(s). | Purge chambers through tapped chamber vent plugs. |

For additional troubleshooting tips contact After Sales Support at service.warrenrupp@idexcorp.com or 419-524-8388

Composite Repair Parts Drawing

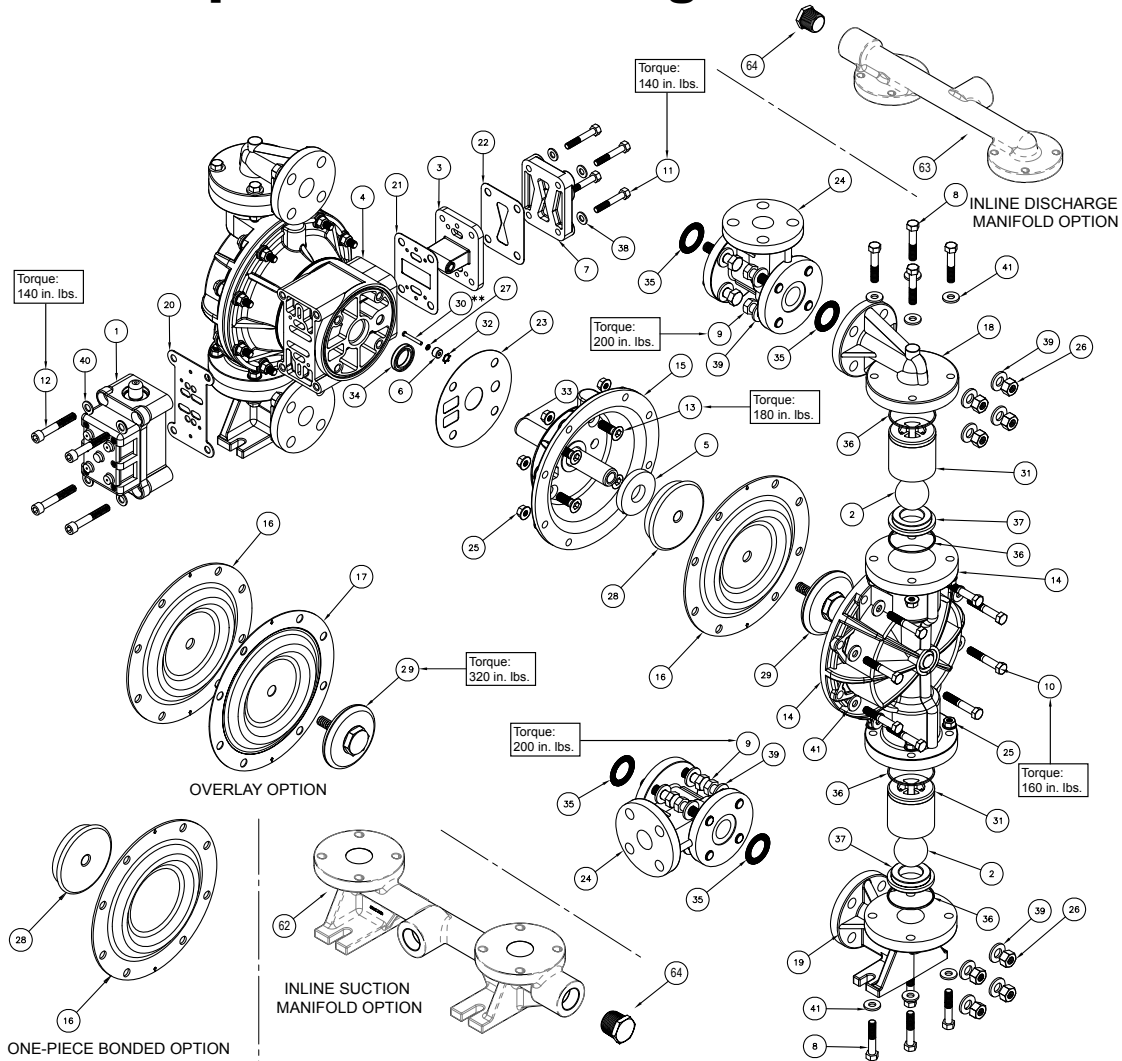

3: EXP VIEW

Service & Repair Kits

- 476-217-000 Air End Kit** (For Polypropylene Center Section)
Seals, O-Rings, Gaskets, Retaining Rings, Air Valve Sleeve & Spool Set and Pilot Valve Assembly
- 476-218-000 Air End Kit** (Stroke Indicator Option, For Polypropylene Center Section)
Seals, O-Rings, Gaskets, Retaining Rings, Air Valve, Sleeve & Spool Set and Pilot Valve Assembly
- 476-197-354 Wetted End Kit**
Santoprene Diaphragms, Santoprene Balls and PTFE Seals
- 476-197-360 Wetted End Kit**
Nitrile Diaphragms, Nitrile Balls and PTFE Seals
- 476-197-363 Wetted End Kit**
FKM Diaphragms, FKM Balls and PTFE Seals
- 476-197-365 Wetted End Kit**
Neoprene Diaphragms, Neoprene Balls and PTFE Seals
- 476-197-635 Wetted End Kit**
Neoprene Diaphragms, PTFE Overlay Diaphragms, PTFE Balls and PTFE Seals

- 476-197-654 Wetted End Kit**
Santoprene Diaphragms, PTFE Overlay Diaphragms, TFE Balls and TFE Seals
- 476-197-659 Wetted End Kit**
One-Piece Bonded Diaphragms, PTFE Balls, PTFE Seals
- 476-198-655 Wetted End Kit**
Santoprene Diaphragms, PTFE Overlay Diaphragms, PTFE Pumping Diaphragms, PTFE Balls and PTFE Seals
- 476-198-354 Wetted End Kit**
Santoprene Diaphragms, Santoprene Pumping Diaphragms, Santoprene Check Balls and PTFE Seals
- 476-198-659 Wetted End Kit**
One-Piece Bonded Diaphragms, PTFE Pumping Diaphragms, PTFE Balls, PTFE Seals
- Electronic Leak Detector Kits**
 - 032-037-000 110 VAC / 220 VAC
 - 032-045-000 12 - 32 VDC

Note: Polypropylene pumps are shipped with the 1" NPT Pipe Plug (Item 64) installed in the end ports of both suction and discharge one-piece manifolds. To convert to the Inline porting positions for pump installation and operation, first remove the pipe plugs and re-install in the center ports. Apply PTFE tape or pipe sealant to threads of the plug before installation.

Composite Repair Parts List

| Item | Part Number | Description | Qty | Item | Part Number | Description | Qty |
|------|---------------|---|-----|------|---------------|--|-----|
| ① | 031-140-000 | Air Valve Assembly | 1 | 19 | 312-113-520 | Elbow, Suction | 2 |
| | ▲ 031-140-001 | Air Valve Assembly (No Muffler) | 1 | | ▲ 312-113-521 | Elbow, Suction | 2 |
| | 031-140-002 | Air Valve Assembly w/PTFE Coated Hardware | 1 | | 312-113-552 | Elbow, Suction (not used with inline option) | 2 |
| | 031-141-000 | Air Valve Assembly (No Muffler) | 1 | | ▲ 312-113-557 | Elbow, Suction | 1 |
| | ▲ 031-141-001 | Air Valve Assembly (No Muffler) | 1 | ⑳ | 360-093-360 | Gasket, Air Valve | 1 |
| | 031-141-002 | Air Valve Assembly (No Muffler / PTFE Hardware) | 1 | ㉑ | 360-103-360 | Gasket, Pilot Valve | 1 |
| | ▲ 031-146-000 | Air Valve Assembly (With Stroke Indicator Option) | 1 | ㉒ | 360-104-360 | Gasket, Air Inlet | 1 |
| | ▲ 031-147-000 | Air Valve Assembly (With Stroke Indicator Option) | 1 | ㉓ | 360-104-379 | Gasket, Air Inlet | 1 |
| | | | | 24 | 360-107-360 | Gasket, Inner Chamber | 2 |
| ② | 050-042-354 | Ball, Check | 4 | | 518-179-520 | Manifold | 2 |
| | 050-042-360 | Ball, Check | 4 | | ▲ 518-179-521 | Manifold | 2 |
| | 050-042-363 | Ball, Check | 4 | | 518-179-552 | Manifold | 2 |
| | 050-042-365 | Ball, Check | 4 | | ▲ 518-179-557 | Manifold | 2 |
| | 050-042-600 | Ball, Check | 4 | 25 | 544-002-115 | Nut, Hex 3/8 - 16 | 32 |
| ③ | 095-110-558 | Pilot Valve Assembly | 1 | | 544-002-308 | Nut, Hex 3/8 - 16 | 32 |
| 4 | 114-024-551 | Intermediate Assembly | 1 | 26 | 545-008-115 | Nut, Hex 1/2 - 13 (not used with inline option) | 16 |
| | ▲ 114-024-559 | Intermediate Assembly | 1 | | 545-008-308 | Nut, Hex 1/2 - 13 (not used with inline option) | 16 |
| ⑤ | 132-035-360 | Bumper, Diaphragm | 2 | ㉗ | 560-001-360 | O-Ring | 2 |
| ⑥ | 135-034-506 | Bushing, Plunger | 2 | 28 | 612-200-157 | Inner Diaphragm Plate | 2 |
| 7 | 165-125-551 | Cap, Air Inlet | 1 | | 612-200-082 | Inner Diaphragm Plate | 2 |
| | ▲ 165-125-559 | Cap, Air Inlet | 1 | | 612-220-150 | Inner Diaphragm Plate (One-Piece Bonded Option) | 2 |
| 8 | 170-020-115 | Capscrew, Hex HD 3/8 - 16 x 2.00 | 16 | 29 | 612-204-520 | Outer Diaphragm Plate | 2 |
| | 170-020-308 | Capscrew, Hex HD 3/8 - 16 x 2.00 | 16 | | 612-204-552 | Outer Diaphragm Plate | 2 |
| 9 | 170-030-115 | Capscrew, Hex HD 1/2 - 13 x 2.00 (not used with inline option) | 16 | ③⑩ | 620-020-115 | Plunger, Actuator | 2 |
| | 170-030-308 | Capscrew, Hex HD 1/2 - 13 x 2.00 (not used with inline option) | 16 | 31 | 670-048-520 | Retainer, Ball | 4 |
| 10 | 170-052-115 | Capscrew, Hex HD 3/8 - 16 x 2.25 | 16 | | 670-048-552 | Retainer, Ball | 4 |
| | 170-052-308 | Capscrew, Hex HD 3/8 - 16 x 2.25 | 16 | ③② | 675-042-115 | Ring, Retainer | 2 |
| 11 | 170-069-115 | Capscrew, Hex HD 5/16 - 18 x 1.75 | 4 | 33 | 685-058-120 | Rod, Diaphragm | 1 |
| | 170-069-308 | Capscrew, Hex HD 5/16 - 18 x 1.75 | 4 | ③④ | 720-004-360 | Seal, Diaphragm Rod | 2 |
| 12 | 171-053-115 | Capscrew, Soc HD 3/8 - 16 x 2.50 | 4 | ③⑤ | 720-044-600 | Seal, Manifold Spacer (not used with inline option) | 4 |
| 13 | 171-015-115 | Capscrew, Soc HD 3/8 - 16 x .88 | 8 | ③⑥ | 720-047-600 | Seal, Check Valve | 8 |
| | 171-015-308 | Capscrew, Soc HD 3/8 - 16 x .88 | 8 | 37 | 722-079-520 | Seat, Check Valve | 4 |
| 14 | 196-157-520 | Chamber, Outer | 2 | | 722-079-552 | Seat, Check Valve | 4 |
| | ▲ 196-157-521 | Chamber, Outer | 2 | 38 | 901-038-115 | Washer, Flat 5/16" | 4 |
| | 196-157-552 | Chamber, Outer | 2 | | 901-038-308 | Washer, Flat 5/16" | 4 |
| | ▲ 196-157-557 | Chamber, Outer | 2 | 39 | 901-046-115 | Washer, Flat 1/2" (not used with inline option) | 32 |
| 15 | 196-177-551 | Chamber, Inner | 2 | | 901-046-308 | Washer, Flat 1/2" (not used with inline option) | 32 |
| | ▲ 196-177-559 | Chamber, Inner | 2 | 40 | 901-048-115 | Washer, Flat 3/8" | 4 |
| ①⑥ | 286-107-354 | Diaphragm | 2 | | 901-048-308 | Washer, Flat 3/8" | 4 |
| | 286-107-360 | Diaphragm | 2 | 41 | 901-049-115 | Washer, Flat 3/8" | 32 |
| | 286-115-000 | Diaphragm, One-Piece Bonded | 2 | | 901-049-308 | Washer, Flat 3/8" | 32 |
| | 286-107-363 | Diaphragm | 2 | 62 | 518-203-552 | Manifold, Suction (Inline Porting Option ONLY) | 1 |
| | 286-107-365 | Diaphragm | 2 | | 518-204-552 | Manifold, Discharge (Inline Porting Option ONLY) | 1 |
| ①⑦ | 286-108-600 | Diaphragm, Overlay | 2 | 64 | 618.057.552 | Plug, 1" NPT Pipe (Inline Porting Option ONLY) | 2 |
| 18 | 312-104-520 | Elbow | 2 | | | | |
| | ▲ 312-104-521 | Elbow | 2 | | | | |
| | ▲ 312-104-557 | Elbow | 2 | | | | |
| | 312-104-552 | Elbow (not used with inline option) | 2 | | | | |

LEGEND:

○ = Items contained within Air End Kits

□ = Items contained within Wet End Kits

Note: Kits contain components specific to the material codes.

⊕ ATEX Compliant

Material Codes - The Last 3 Digits of Part Number

000.....Assembly, sub-assembly;
and some purchased items

010.....Cast Iron

015.....Ductile Iron

020.....Ferritic Malleable Iron

080.....Carbon Steel, AISI B-1112

110.....Alloy Type 316 Stainless Steel

111.....Alloy Type 316 Stainless Steel
(Electro Polished)

112.....Alloy C

113.....Alloy Type 316 Stainless Steel
(Hand Polished)

114.....303 Stainless Steel

115.....302/304 Stainless Steel

117.....440-C Stainless Steel (Martensitic)

120.....416 Stainless Steel
(Wrought Martensitic)

148.....Hardcoat Anodized Aluminum

150.....6061-T6 Aluminum

152.....2024-T4 Aluminum (2023-T351)

155.....356-T6 Aluminum

156.....356-T6 Aluminum

157.....Die Cast Aluminum Alloy #380

158.....Aluminum Alloy SR-319

162.....Brass, Yellow, Screw Machine Stock

165.....Cast Bronze, 85-5-5-5

166.....Bronze, SAE 660

170.....Bronze, Bearing Type,
Oil Impregnated

180.....Copper Alloy

305.....Carbon Steel, Black Epoxy Coated

306.....Carbon Steel, Black PTFE Coated

307.....Aluminum, Black Epoxy Coated

308.....Stainless Steel, Black PTFE Coated

309.....Aluminum, Black PTFE Coated

313.....Aluminum, White Epoxy Coated

330.....Zinc Plated Steel

332.....Aluminum, Electroless Nickel Plated

333.....Carbon Steel, Electroless
Nickel Plated

335.....Galvanized Steel

337.....Silver Plated Steel

351.....Food Grade Santoprene®

353.....Geolast; Color: Black

354.....Injection Molded #203-40
Santoprene® Duro 40D +/-5;
Color: RED

356.....Hytrel®

357.....Injection Molded Polyurethane

358.....Urethane Rubber
(Some Applications)
(Compression Mold)

359.....Urethane Rubber

360.....Nitrile Rubber Color coded: RED

363.....FKM (Fluorocarbon)
Color coded: YELLOW

364.....EPDM Rubber
Color coded: BLUE

365.....Neoprene Rubber
Color coded: GREEN

366.....Food Grade Nitrile

368.....Food Grade EPDM

371.....Philthane (Tuftane)

374.....Carboxylated Nitrile

375.....Fluorinated Nitrile

378.....High Density Polypropylene

379.....Conductive Nitrile

408.....Cork and Neoprene

425.....Compressed Fibre

426.....Blue Gard

440.....Vegetable Fibre

500.....Delrin® 500

502.....Conductive Acetal, ESD-800

503.....Conductive Acetal, Glass-Filled

506.....Delrin® 150

520.....Injection Molded PVDF
Natural color

540.....Nylon

542.....Nylon

544.....Nylon Injection Molded

550.....Polyethylene

551.....Glass Filled Polypropylene

552.....Unfilled Polypropylene

555.....Polyvinyl Chloride

556.....Black Vinyl

557.....Unfilled Conductive Polypropylene

558.....Conductive HDPE

559.....Glass-Filled Conductive Polypropylene

570.....Rulon II®

580.....Ryton®

600.....PTFE (virgin material)
Tetrafluorocarbon (TFE)

603.....Blue Gylon®

604.....PTFE

606.....PTFE

607.....Envelon

608.....Conductive PTFE

610.....PTFE Encapsulated Silicon

611.....PTFE Encapsulated FKM

632.....Neoprene/Hytrel®

633.....FKM/PTFE

634.....EPDM/PTFE

635.....Neoprene/PTFE

637.....PTFE, FKM/PTFE

638.....PTFE, Hytrel®/PTFE

639.....Nitrile/TFE

643.....Santoprene®/EPDM

644.....Santoprene®/PTFE

656.....Santoprene® Diaphragm and
Check Balls/EPDM Seats

661.....EPDM/Santoprene®

666.....FDA Nitrile Diaphragm,

PTFE Overlay, Balls, and Seals

668.....PTFE, FDA Santoprene®/PTFE

- Delrin and Hytrel are registered tradenames of E.I. DuPont.
- Nylatron is a registered tradename of Polymer Corp.
- Gylon is a registered tradename of Garlock, Inc.
- Santoprene is a registered tradename of Exxon Mobil Corp.
- Rulon II is a registered tradename of Dixon Industries Corp.
- Ryton is a registered tradename of Phillips Chemical Co.
- Valox is a registered tradename of General Electric Co.

RECYCLING

Many components of SANDPIPER® AODD pumps are made of recyclable materials. We encourage pump users to recycle worn out parts and pumps whenever possible, after any hazardous pumped fluids are thoroughly flushed.

Spill Containment Options

Virgin PTFE Equipped Pumps

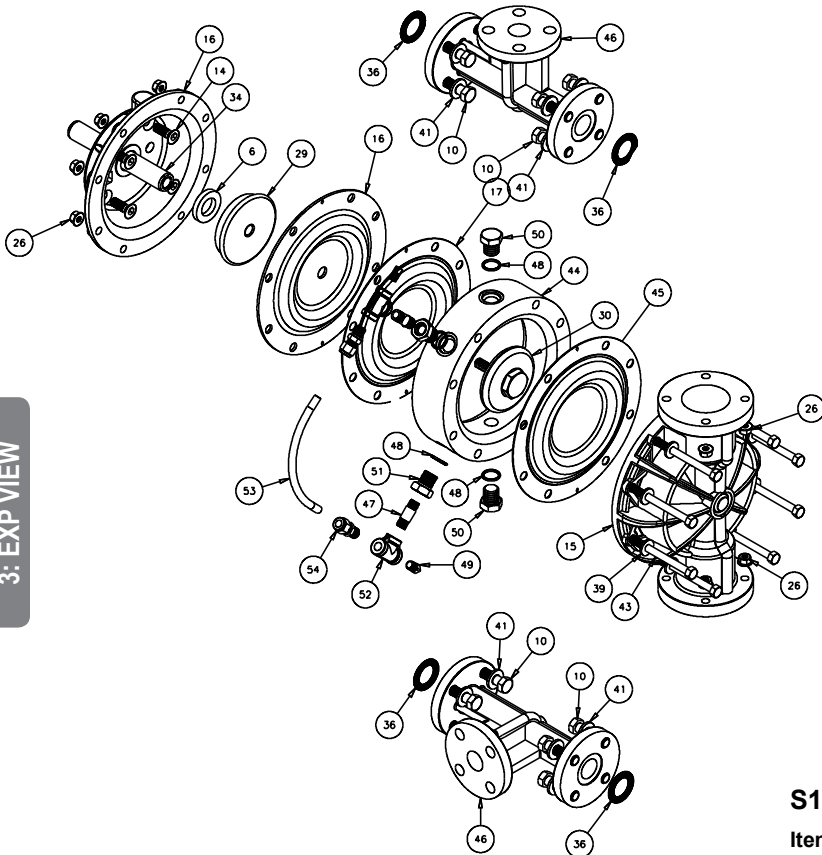

IMPORTANT



Read these instructions completely, before installation and start-up. It is the responsibility of the purchaser to retain this manual for reference. Failure to comply with the recommendations stated in this manual will damage the pump, and void factory warranty.

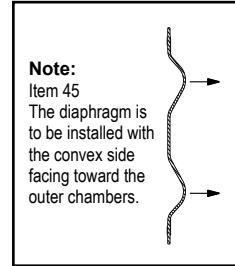

Note:
Item 45
The diaphragm is to be installed with the convex side facing toward the outer chambers.

Santoprene Equipped Pumps

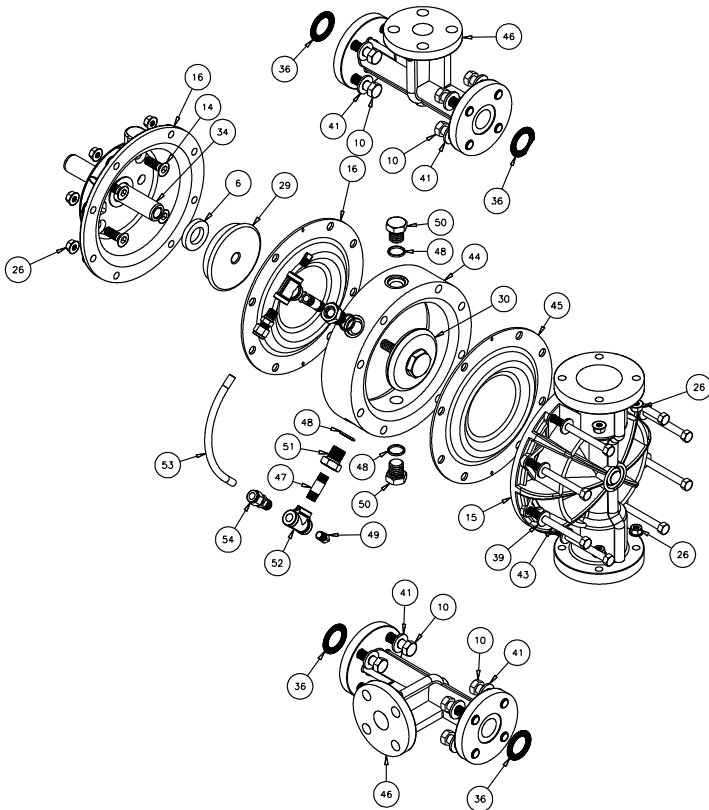

S1F Spill Containment Repair Parts List

| Item | Part Number | Description | Qty |
|------|-------------|---|-----|
| 43 | 170-114-115 | Capscrew, Hex HD 3/8 - 16 x 4.75 (Replace 170-052-115) | 16 |
| | 170-114-308 | Capscrew, Hex HD 3/8 - 16 x 4.75 (Replace 170-052-115) | 16 |
| 44 | 196-159-552 | Chamber, Spill Containment | 2 |
| | 196-159-520 | Chamber, Spill Containment | 2 |
| 45 | 286-094-600 | Diaphragm, Pumping (PTFE Only) | 2 |
| | 286.092.354 | Diaphragm, Pumping (Santoprene Only) | 2 |
| 46 | 518-180-520 | Manifold, Spill Containment | 2 |
| | 518-180-552 | Manifold, Spill Containment (Replace 518-179-520) | 2 |
| 47 | 538-022-110 | Nipple, Pipe | 4 |
| | 538-022-308 | Nipple, Pipe | 4 |
| 48 | 560-078-611 | O-Ring | 8 |
| 49 | 618-003-110 | Plug, Pipe | 4 |
| | 618-003-308 | Plug, Pipe | 4 |
| 50 | 618-025-110 | Plug, Boss | 4 |
| | 618-025-308 | Plug, Boss | 4 |
| 51 | 618-031-110 | Threaded Bushing | 4 |
| | 618-031-308 | Threaded Bushing | 4 |
| 52 | 835-005-110 | Tee, Pipe | 4 |
| | 835-005-308 | Tee, Pipe | 4 |
| 53 | 860-056-606 | Tube, Sight | 2 |
| 54 | 866-060-110 | Connector, Tube | 4 |

*Note: The Diaphragm is to be installed with the convex side facing toward the outer chamber. See drawing.

Note: Pump units with One-Piece Bonded Diaphragm option will not include Overlay Diaphragms (Items 17) and Outer Diaphragm Plate (Item 29).

3: EXP VIEW

Spill Containment Servicing

Read these instructions completely, before installation and start-up. It is the responsibility of the purchaser to retain this manual for reference. Failure to comply with the recommendations stated in this manual will damage the pump, and void factory warranty.

Step 1: With the unit removed from service. Remove each bottom boss plug (item 51). Drain the fluid from spill containment chambers. With manifolds and outer chambers removed, remove diaphragm assemblies from diaphragm rod.

DO NOT use a pipe wrench or similar tool to remove assembly from rod. Flaws in the rod surface may damage bearings and seal. Soft jaws in a vise are recommended to prevent diaphragm rod damage.

Step 1.A: NOTE: Not all inner diaphragm plates are threaded. Some models utilize a through hole in the inner diaphragm plate. If required to separate diaphragm assembly, place assembly in a vise, gripping on the exterior cast diameter of the inner plate. Turn the outer plate clockwise to separate the assembly.

Always inspect diaphragms for wear cracks or chemical attack. Inspect inner and outer plates for deformities, rust scale and wear. Inspect intermediate bearings for elongation and wear. Inspect diaphragm rod for wear or marks. Clean or repair if appropriate. Replace as required.

Step 2: Reassembly: There are two different types of diaphragm plate assemblies utilized throughout the Sandpiper product line: Outer plate with a threaded stud, diaphragm, and a threaded inner plate. Outer plate with a threaded stud, diaphragm, and an inner plate with through hole. Secure threaded inner plate in a vise. Ensure that the plates are being installed with the outer radius against the diaphragm.

Step 3: Lightly lubricate, with a compatible material, the inner faces of both outer and inner diaphragm plates when using on non-Overlay diaphragms (For EPDM water is recommended). No lubrication is required.

Step 4: Push the threaded outer diaphragm plate through the center hole of the diaphragm.
Note: Most diaphragms are installed with the natural bulge out towards the fluid side.

Step 5: Thread or place, outer plate stud into the inner plate. For threaded inner plates, use a torque wrench to tighten the assembly together. Torque values are called out on the exploded view. Repeat procedure for second side assembly. Allow a minimum of 15 minutes to elapse after torquing, and then re-torque the assembly to compensate for stress relaxation in the clamped assembly.

Step 6: Thread one assembly onto the diaphragm rod with sealing washer (when used) and bumper.

Step 7: Install diaphragm rod assembly into pump and reassemble containment chamber then the pumping diaphragms (item 45) secure by installing the outer chamber in place and tightening the capscrews. Replace bottom boss plug (item 51) and O-Ring (item 48) **NOTE:** The spill containment option has two additional pumping diaphragms (item 45). These diaphragms are installed with the natural concave curve toward the outer chamber.

Step 8: On opposite side of pump, thread the remaining assembly onto the diaphragm rod. Using a torque wrench, tighten the assembly to the diaphragm rod. Align diaphragm through bolt holes, always going forward past the recommended torque. Torque values are called out on the exploded view. **NEVER** reverse to align holes, if alignment cannot be achieved without damage to diaphragm, loosen complete assemblies, rotate diaphragm and reassemble as described above.

Step 9: Reassemble containment chamber then the pumping diaphragms (item 45) secure by installing the outer chamber in place and tightening the capscrews. Replace bottom boss plug (item 51) and new O-Ring (item 48).

NOTE: The spill containment option has two additional virgin pumping diaphragms (item 45). PTFE diaphragms are installed with the natural concave curve toward the outer chamber.

NOTE: One Piece Diaphragm Servicing (Bonded PTFE with integral plate) The One Piece diaphragm has a threaded stud installed in the integral plate at the factory. The inner diaphragm plate has a through hole instead of a threaded hole. Place the inner plate over the diaphragm stud and thread the first diaphragm / inner plate onto the diaphragm rod only until the inner plate contacts the rod. Do not tighten. A small amount of grease may be applied between the inner plate and the diaphragm to facilitate assembly. Insert the diaphragm / rod assembly into the pump and install the outer chamber. Turn the pump over and thread the second diaphragm / inner plate onto the diaphragm rod. Turn the diaphragm until the inner plate contacts the rod and hand tighten the assembly. Continue tightening until the bolt holes align with the inner chamber holes. **DO NOT LEAVE THE ASSEMBLY LOOSE.**

FILLING CHAMBERS WITH LIQUID

THE CHAMBERS ARE FILLED WITH WATER AT THE FACTORY.

If you prefer to substitute another liquid, to prevent system contamination consult the factory first to determine compatibility of the substitute with pump construction.

Follow the steps listed here to replace the liquid in the pump after disassembly or liquid loss:

10. With the top two boss plugs (items 50) removed. The spill containment chambers are filled through the exposed ports.

11. Install safety clip (item 1-K) into the smaller unthreaded hole in one end cap (item 1-E). This locks the valve spool to one side, keeping the pump from shifting. Apply air pressure to the air distribution valve.

12. Face the side of the pump with the installed safety clip. If the safety clip is installed in the top end cap, fill the left spill containment chamber. If the safety clip is installed on the bottom end cap, fill the right spill containment chamber. The volume of fluid is 1198 ml (40.49 fl. oz.). It is important that the exact amount of fluid is used. Too little or too much fluid causes premature diaphragm failure and erratic pumping.

13. Loosely reinstall one boss plug (item 50) to the filled spill containment chamber.

14. Shut off air supply. Remove safety clip. Manually shift air valve by pushing stroke indicator pin in the opposite direction of current position. Install safety clip (item 1-K) into the smaller unthreaded hole in the opposite end cap (item 1-E). This locks the valve spool to one side, keeping the pump from shifting. Adjust the airline regulator so that air pressure slowly fills the pump. The diaphragm expands, forcing the fluid in the chamber to be slowly displaced.

15. Loosen the top boss plug on the filled chambers. This allows fluid in the chamber to purge trapped air from the chamber. This can be seen by watching the column of fluid in the sight tube. When fluid appears at the top of the port, quickly tighten the boss plug. Fluid loss of 1 to 2ml is acceptable.

16. Tilt the pump so the uppermost pipe tee (item 52) is in the vertical position. Loosen the pipe plug (item 49). This will allow trapped air to purge through the pipe tee. When fluid appears at the tee opening, reinstall the pipe plug. **NOTE:** If all air is not purged using this procedure, remove the check valve components from the top port of the outer chamber (item 44). Apply manual pressure to the pumping diaphragm by inserting a blunt instrument into the top port of the outer chamber and applying pressure to the diaphragm. Loosen the pipe plug (item 49) allowing the fluid to purge any remaining trapped air. Reinstall the plug.

17. Repeat steps 12 through 16 to fill opposite spill containment chamber.

18. Reinstall the check valve components, discharge manifold and elbows to the pump. The pump is now ready for operation.

Air Distribution Valve Assembly

4: AIR END

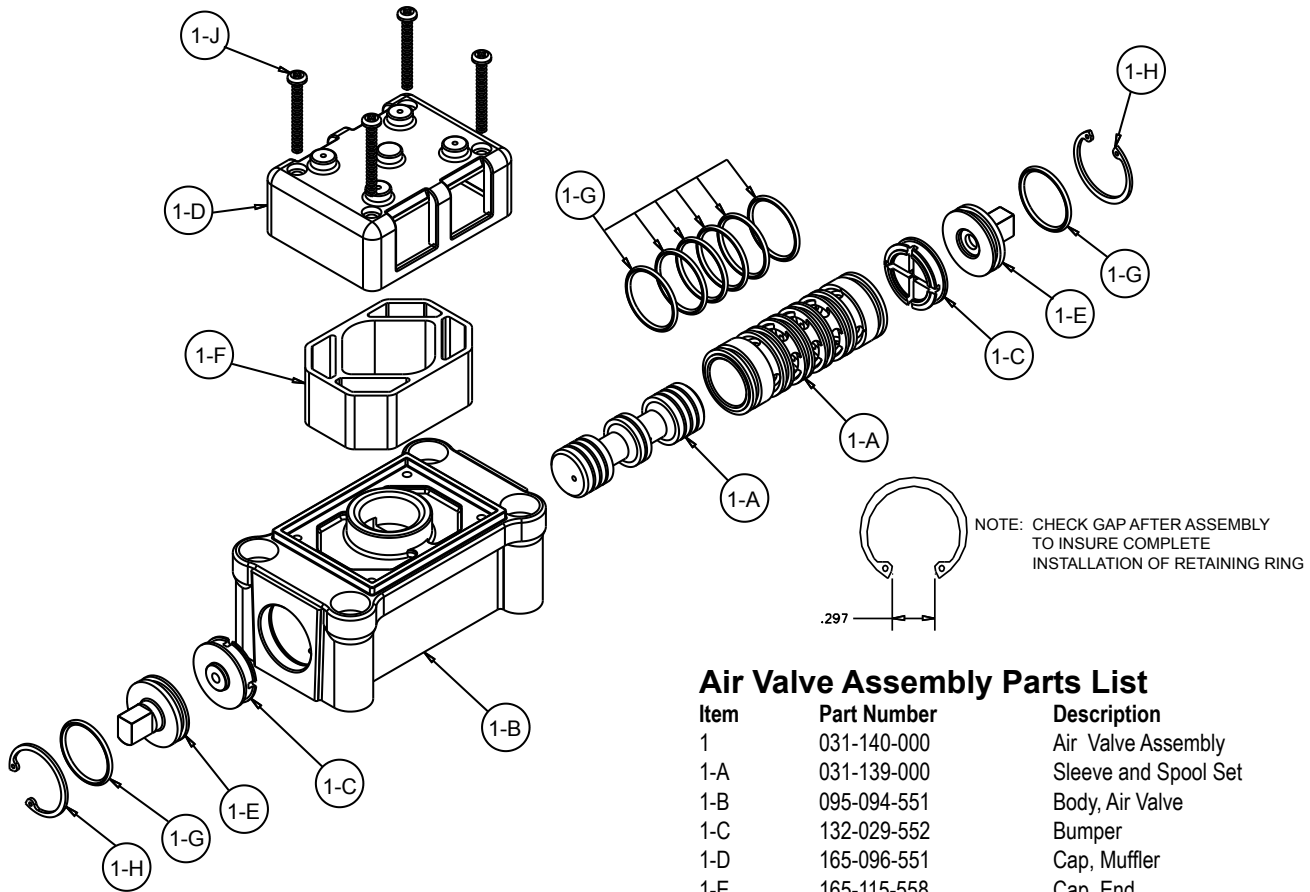

Air Distribution Valve Servicing

See repair parts drawing, remove screws.

Step 1: Remove end cap retainer (1-H).

Step 2: Remove end cap (1-E).

Step 3: Remove spool part of (1-A) (caution: do not scratch).

Step 4: Press sleeve (1-A) from body (1-B).

Step 5: Inspect O-Ring (1-H) and replace if necessary.

Step 6: Lightly lubricate O-Rings (1-H) on sleeve (1-A).

Step 7: Press sleeve (1-A) into body (1-B).

Step 8: Reassemble in reverse order, starting with step 3.

Note: Sleeve and spool (1-A) set is match ground to a specified clearance sleeve and spools (1-A) cannot be interchanged.

IMPORTANT



Read these instructions completely, before installation and start-up. It is the responsibility of the purchaser to retain this manual for reference. Failure to comply with the recommendations stated in this manual will damage the pump, and void factory warranty.

Air Valve Assembly Parts List

| Item | Part Number | Description | Qty |
|------|-------------|----------------------|-----|
| 1 | 031-140-000 | Air Valve Assembly | 1 |
| 1-A | 031-139-000 | Sleeve and Spool Set | 1 |
| 1-B | 095-094-551 | Body, Air Valve | 1 |
| 1-C | 132-029-552 | Bumper | 2 |
| 1-D | 165-096-551 | Cap, Muffler | 1 |
| 1-E | 165-115-558 | Cap, End | 2 |
| 1-F | 530-028-550 | Muffer | 1 |
| 1-G | 560-020-360 | O-Ring | 8 |
| 1-H | 675-044-115 | Ring, Retaining | 2 |
| 1-J | 710-015-115 | Screw, Self-tapping | 4 |

For Pumps with Alternate Mesh, Sound Dampening Mufflers or Piped Exhaust:

| | | | |
|---|-------------|--------------------|---|
| 1 | 031-141-000 | Air Valve Assembly | 1 |
|---|-------------|--------------------|---|

(Includes all items used on 031-140-000 minus items 1-D, 1-F & 1-J)

Air Valve Assembly Parts List

| Item | Part Number | Description | Qty |
|------|-------------|----------------------|-----|
| 1 | 031-140-001 | Air Valve Assembly | 1 |
| 1-A | 031-139-000 | Sleeve and Spool Set | 1 |
| 1-B | 095-094-559 | Body, Air Valve | 1 |
| 1-C | 132-029-552 | Bumper | 2 |
| 1-D | 165-096-559 | Cap, Muffler | 1 |
| 1-E | 165-115-558 | Cap, End | 2 |
| 1-F | 530-028-550 | Muffer | 1 |
| 1-G | 560-020-360 | O-Ring | 8 |
| 1-H | 675-044-115 | Ring, Retaining | 2 |
| 1-J | 710-015-115 | Screw, Self-tapping | 4 |

| | | | |
|---|-------------|--------------------|---|
| 1 | 031-141-001 | Air Valve Assembly | 1 |
|---|-------------|--------------------|---|

(Includes all items used on 031-140-001 minus items 1-D, 1-F & 1-J)



ATEX Compliant

Air Valve with Stroke Indicator Assembly

Note: Stroke Indicator is standard on Spill Containment models

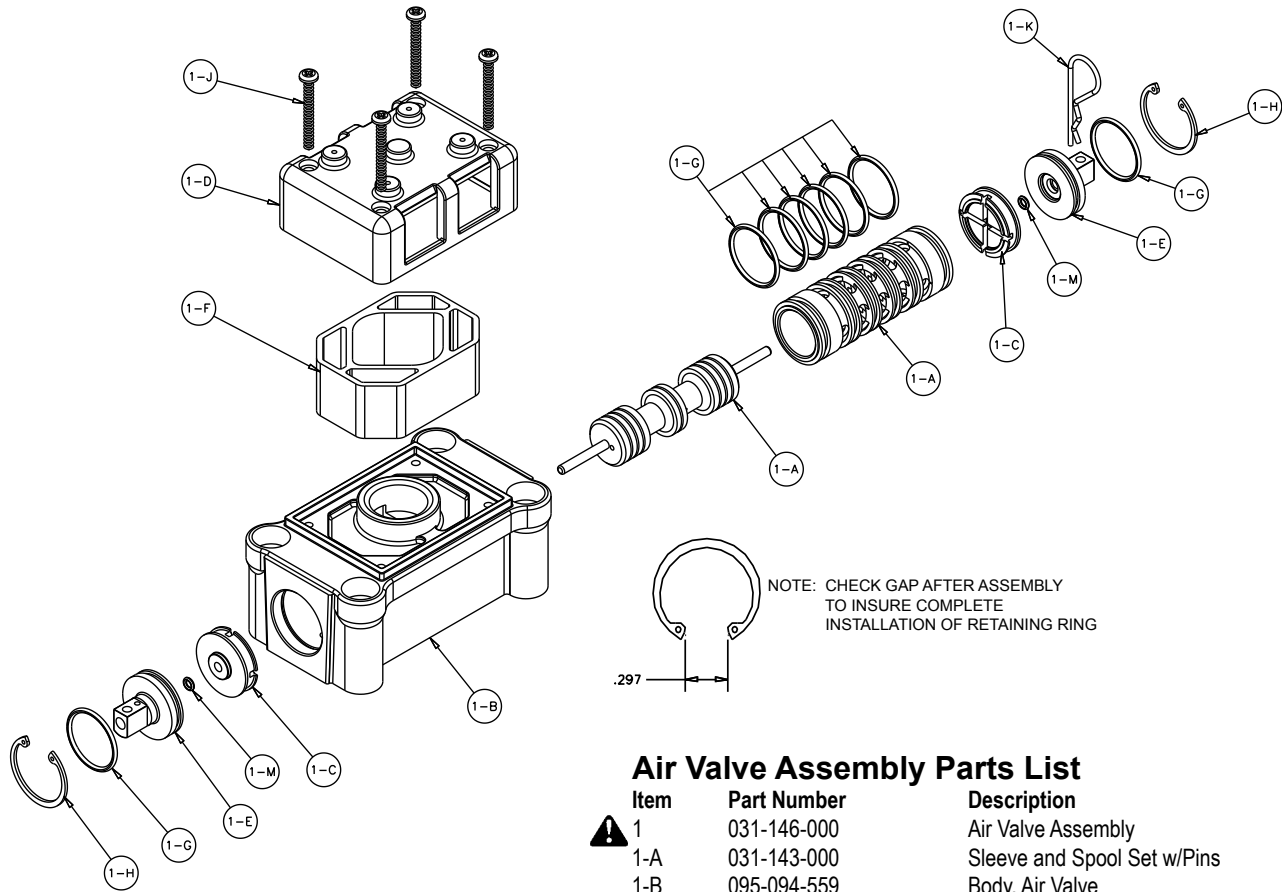

Air Distribution Valve Servicing

See repair parts drawing, remove screws.

Step 1: Remove end cap retainer (1-H).

Step 2: Remove end cap (1-E), bumper (1-C).

Step 3: Remove spool part of (1-A) (caution, do not scratch).

Step 4: Press sleeve (1-A) from body (1-B).

Step 5: Inspect O-Ring (1-G) and replace if necessary.

Step 6: Lightly lubricate O-Rings (1-G) on sleeve (1-A).

Step 7: Press sleeve (1-A) into body (1-B).

Step 8: Reassemble in reverse order.

Note: Sleeve and spool (1-A) set is match ground to a specified clearance sleeve and spools (1-A) cannot be interchanged.

Air Valve Assembly Parts List

| Item | Part Number | Description | Qty |
|------|-------------|-----------------------------|-----|
| ⚠ 1 | 031-146-000 | Air Valve Assembly | 1 |
| 1-A | 031-143-000 | Sleeve and Spool Set w/Pins | 1 |
| 1-B | 095-094-559 | Body, Air Valve | 1 |
| 1-C | 132-029-552 | Bumper | 2 |
| 1-D | 165-096-559 | Cap, Muffer | 1 |
| 1-E | 165-098-147 | Cap, End | 2 |
| 1-F | 530-028-550 | Muffer | 1 |
| 1-G | 560-020-360 | O-Ring | 8 |
| 1-H | 675-044-115 | Ring, Retaining | 2 |
| 1-J | 710-015-115 | Screw, Self-Tapping | 4 |
| 1-K | 210-008-330 | Clip, Safety | 1 |
| 1-M | 560-029-360 | O-Ring | 2 |

For Pumps with PTFE Coated Hardware:

| | | | |
|-----|-------------|---------------------|---|
| 1 | 031-146-002 | Air Valve Assembly | 1 |
| 1-J | 710-015-308 | Screw, Self Tapping | 4 |

(includes all other items on 031-146-000 above)

For Pumps with Alternate Mesh, Sound Dampening Mufflers or Piped Exhaust:

| | | | |
|-----|-------------|--------------------|---|
| ⚠ 1 | 031-147-000 | Air Valve Assembly | 1 |
|-----|-------------|--------------------|---|

(includes all items on 031-146-000 minus 1-D, 1-F, & 1-J)

  **ATEX Compliant**

Pilot Valve Assembly

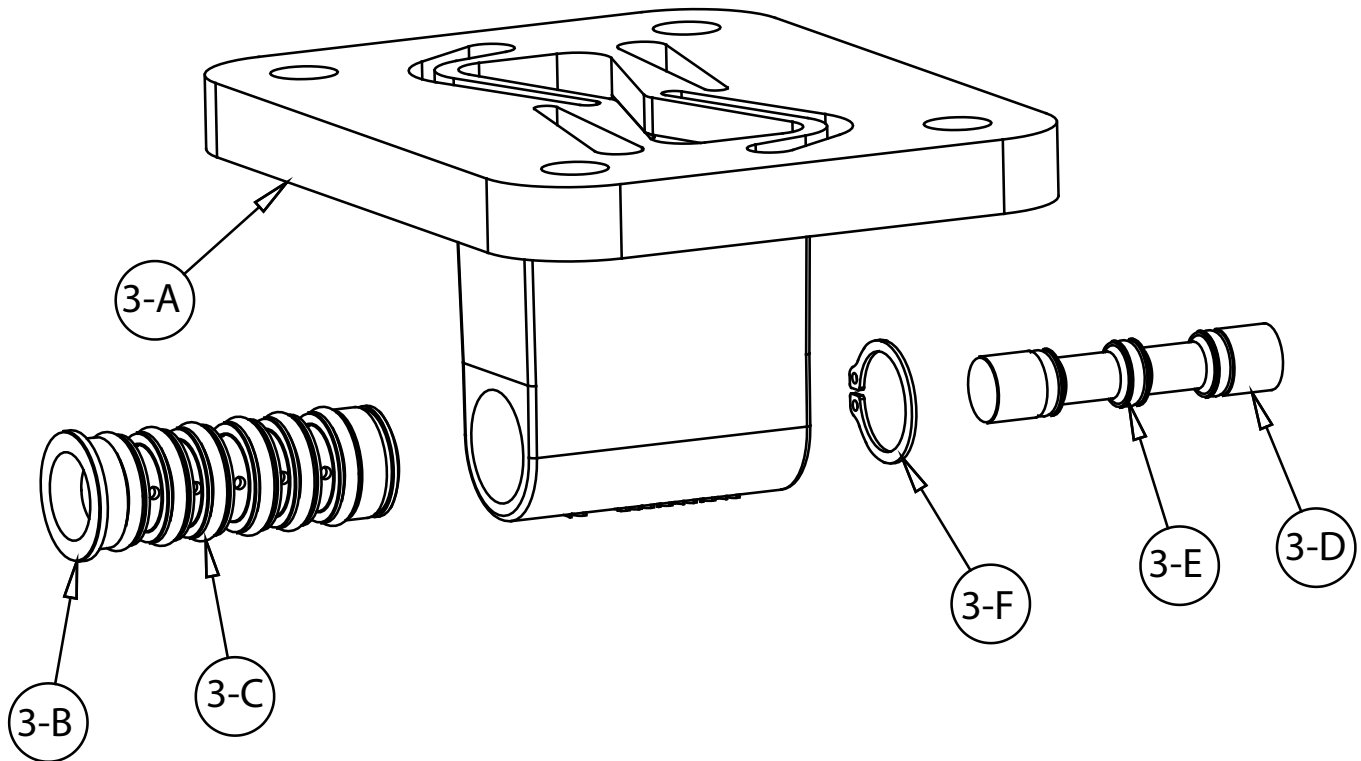

4: AIR END

Pilot Valve Servicing

With Pilot Valve removed from pump.

Step 1: Remove snap ring (3-F).

Step 2: Remove sleeve (3-B), inspect O-Rings (3-C), replace if required.

Step 3: Remove spool (3-D) from sleeve (3-B), inspect O-Rings (3-E), replace if required.

Step 4: Lightly lubricate O-Rings (3-C) and (3-E).

Reassemble in reverse order.

Pilot Valve Assembly Parts List

| Item | Part Number | Description | Qty |
|------|-------------|-----------------------|-----|
| 3 | 095-110-558 | Pilot Valve Assembly | 1 |
| 3-A | 095-095-558 | Valve Body | 1 |
| 3-B | 755-052-000 | Sleeve (With O-Rings) | 1 |
| 3-C | 560-033-360 | O-Ring (Sleeve) | 6 |
| 3-D | 775-055-000 | Spool (With O-Rings) | 1 |
| 3-E | 560-023-360 | O-Ring (Spool) | 3 |
| 3-F | 675-037-080 | Retaining Ring | 1 |

Intermediate Assembly Drawing

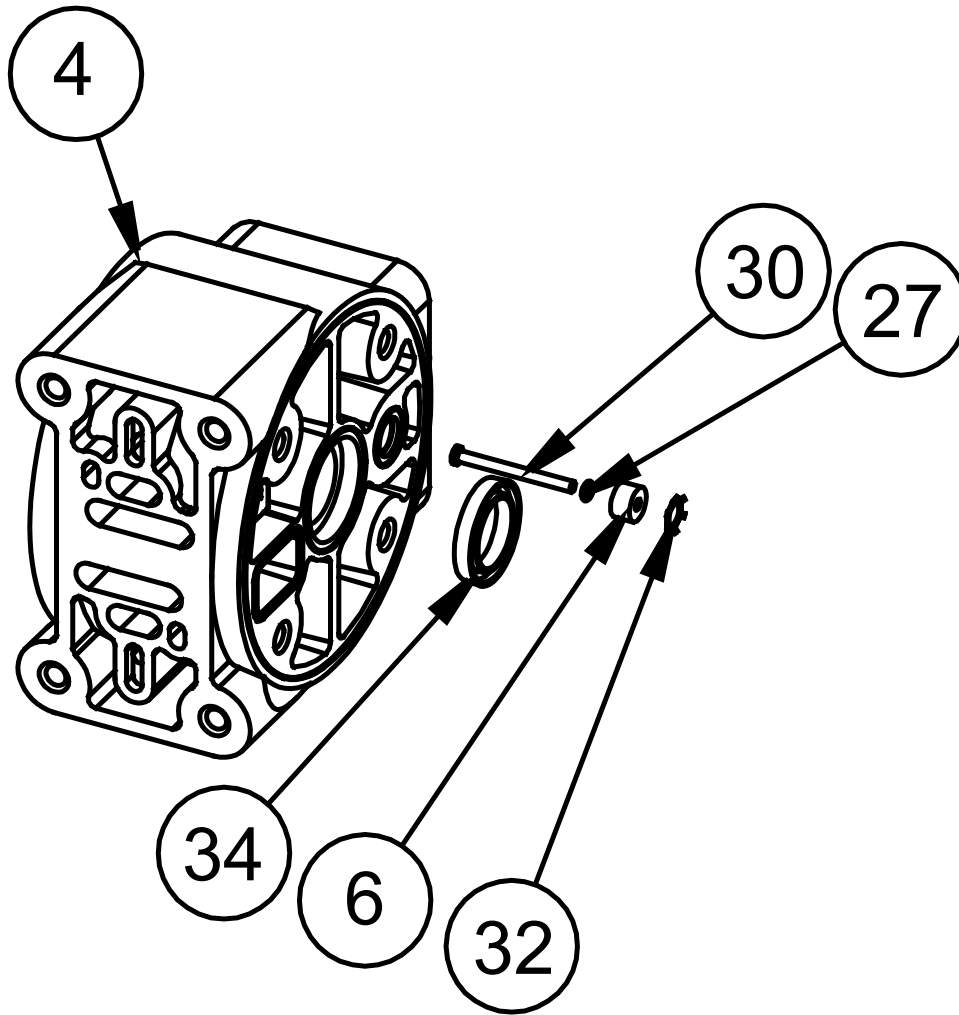

Intermediate Assembly Drawing

- Step 1:** Remove plunger, actuator (30) from center of intermediate pilot valve cavity.
- Step 2:** Remove Ring, Retaining (32), discard.
- Step 3:** Remove bushing, plunger (6), inspect for wear and replace if necessary with genuine parts.
- Step 4:** Remove O-Ring (27), inspect for wear and replace if necessary with genuine parts.
- Step 5:** Lightly lubricate O-Ring (27) and insert into intermediate.
- Step 6:** Reassemble in reverse order.
- Step 7:** Remove Seal, Diaphragm Rod (34).
- Step 8:** Clean seal area, lightly lubricate and install new Seal, Diaphragm Rod (34).

INTERMEDIATE REPAIR PARTS LIST

| Item | Part Number | Description | Qty |
|------|-------------|-----------------------|-----|
| 4 | 114.024.551 | Bracket, Intermediate | 1 |
| | 114.024.559 | Bracket, Intermediate | 1 |
| 6 | 135.034.506 | Bushing, Plunger | 2 |
| 27 | 560.001.360 | O-Ring | 2 |
| 30 | 620.020.115 | Plunger, Actuator | 2 |
| 32 | 675.042.115 | Ring, Retaining* | 2 |
| 34 | 720.004.360 | Seal, Diaphragm Rod | 2 |

***Note:** It is recommended that when plunger components are serviced, new retaining rings be installed.

⚠ IMPORTANT



When the pumped product source is at a higher level than the pump (flooded suction condition), pipe the exhaust higher than the product source to prevent siphoning spills. In the event of a diaphragm failure a complete rebuild of the center section is recommended.

Diaphragm Service Drawing with Overlay

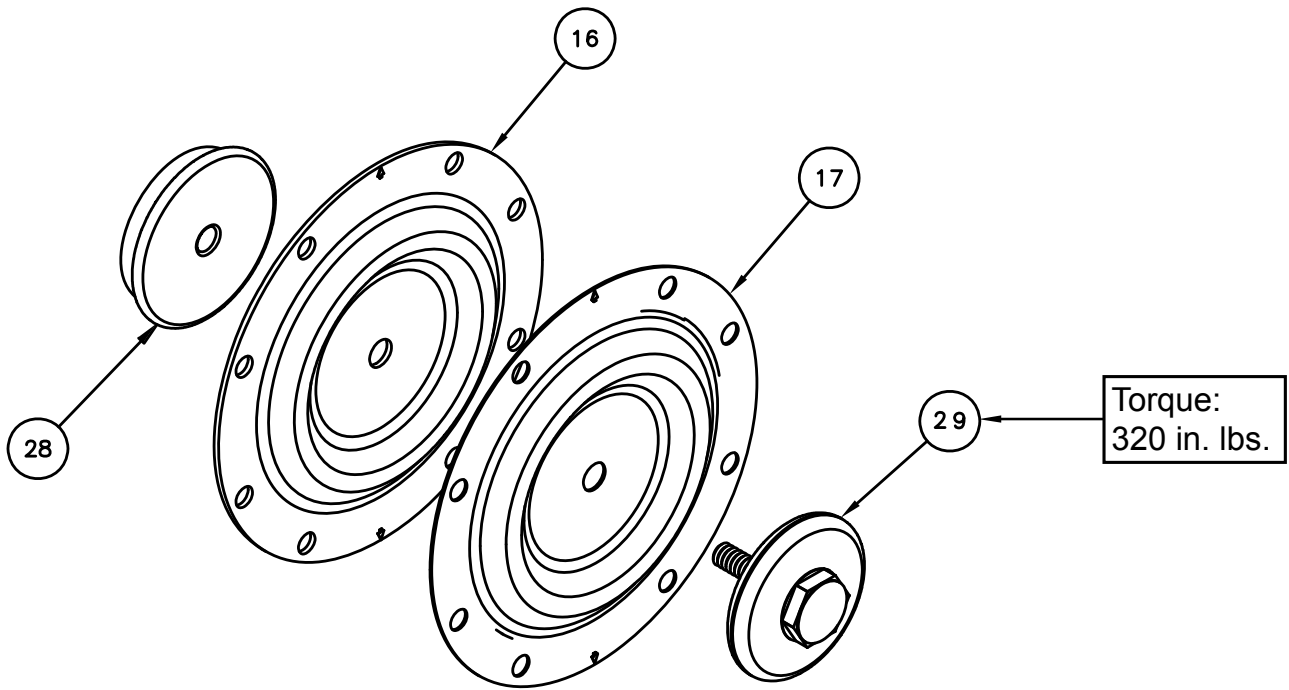

Diaphragm Service Drawing, Non-Overlay

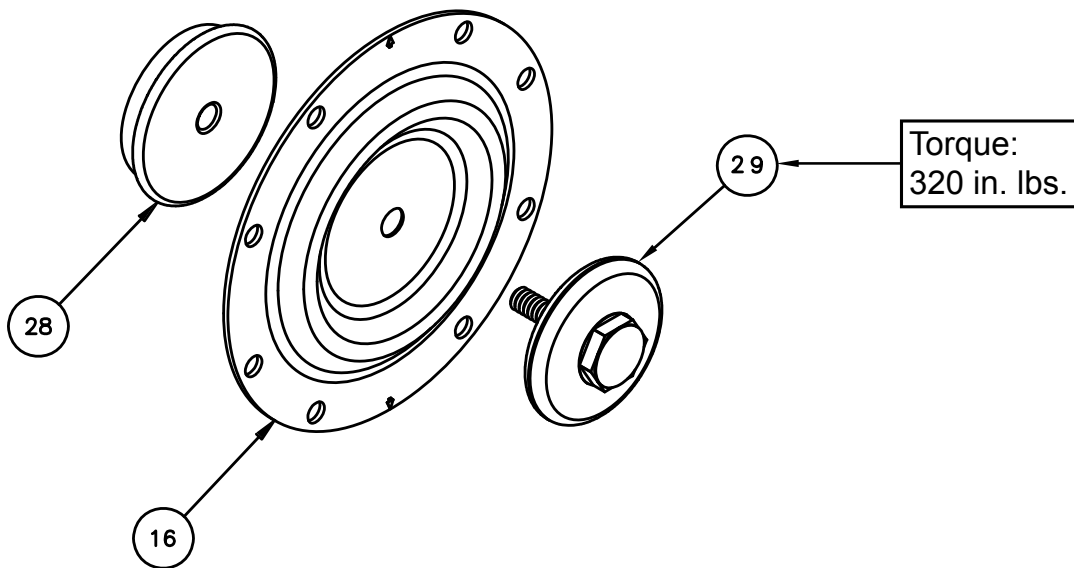

5: WET END

Field conversion kit 475-258-000 available for conversion from PTFE Overlay to One-Piece bonded Diaphragm

| Part | Description | Qty |
|-------------|------------------------|-----|
| 286-115-000 | One-Piece Diaphragm | 2 |
| 612-220-150 | Plate, Inner Diaphragm | 2 |

Diaphragm Servicing

Step 1: With manifolds and outer chambers removed, remove diaphragm assemblies from diaphragm rod. **DO NOT** use a pipe wrench or similar tool to remove assembly from rod. Flaws in the rod surface may damage bearings and seal. Soft jaws in a vise are recommended to prevent diaphragm rod damage.

Step 1.A: NOTE: Not all inner diaphragm plates are threaded. Some models utilize a through hole in the inner diaphragm plate. If required to separate diaphragm assembly, place assembly in a vise, gripping on the exterior cast diameter of the inner plate. Turn the outer plate clockwise to separate the assembly.

Always inspect diaphragms for wear cracks or chemical attack. Inspect inner and outer plates for deformities, rust scale and wear. Inspect intermediate bearings for elongation and wear. Inspect diaphragm rod for wear or marks.

Clean or repair if appropriate. Replace as required.

Step 2: Reassembly: There are two different types of diaphragm plate assemblies utilized throughout the Sandpiper product line: Outer plate with a threaded stud, diaphragm, and a threaded inner plate.

Outer plate with a threaded stud, diaphragm, and an inner plate with through hole. Secure threaded inner plate in a vise. Ensure that the plates are being installed with the outer radius against the diaphragm.

Step 3: Lightly lubricate, with a compatible material, the inner faces of both outer and inner diaphragm plates when using on non Overlay diaphragms (For EPDM water is recommended). No lubrication is required.

Step 4: Push the threaded outer diaphragm plate through the center hole of the diaphragm.

Note: Most diaphragms are installed with the natural bulge out towards the fluid side. S05, S07, and S10 non-metallic units are installed with the natural bulge in towards the air side.

Step 5: Thread or place, outer plate stud into the inner plate. For threaded inner plates, use a torque wrench to tighten the assembly together. Torque values are called out on the exploded view.

Repeat procedure for second side assembly. Allow a minimum of 15 minutes to elapse after torquing, then re-torque the assembly to compensate for stress relaxation in the clamped assembly.

Step 6: Thread one assembly onto the diaphragm rod with sealing washer (when used) and bumper.

Step 7: Install diaphragm rod assembly into pump and secure by installing the outer chamber in place and tightening the capscrews.

Step 8: On opposite side of pump, thread the remaining assembly onto the diaphragm rod. Using a torque wrench, tighten the assembly to the diaphragm rod. Align diaphragm through bolt holes, always going forward past the recommended torque. Torque values are called out on the exploded view. **NEVER** reverse to align holes, if alignment cannot be achieved without damage to diaphragm, loosen complete assemblies, rotate diaphragm and reassemble as described above.

Step 9: Complete assembly of entire unit.

One Piece Diaphragm Servicing (Bonded PTFE with integral plate) The One Piece diaphragm has a threaded stud installed in the integral plate at the factory. The inner diaphragm plate has a through hole instead of a threaded hole. Place the inner plate over the diaphragm stud and thread the first diaphragm / inner plate onto the diaphragm rod only until the inner plate contacts the rod. Do not tighten. A small amount of grease may be applied between the inner plate and the diaphragm to facilitate assembly. Insert the diaphragm / rod assembly into the pump and install the outer chamber. Turn the pump over and thread the second diaphragm / inner plate onto the diaphragm rod. Turn the diaphragm until the inner plate contacts the rod and hand tighten the assembly. Continue tightening until the bolt holes align with the inner chamber holes. **DO NOT LEAVE THE ASSEMBLY LOOSE.**

IMPORTANT



Read these instructions completely, before installation and start-up. It is the responsibility of the purchaser to retain this manual for reference. Failure to comply with the recommendations stated in this manual will damage the pump, and void factory warranty.

Solenoid Shifted Air Valve

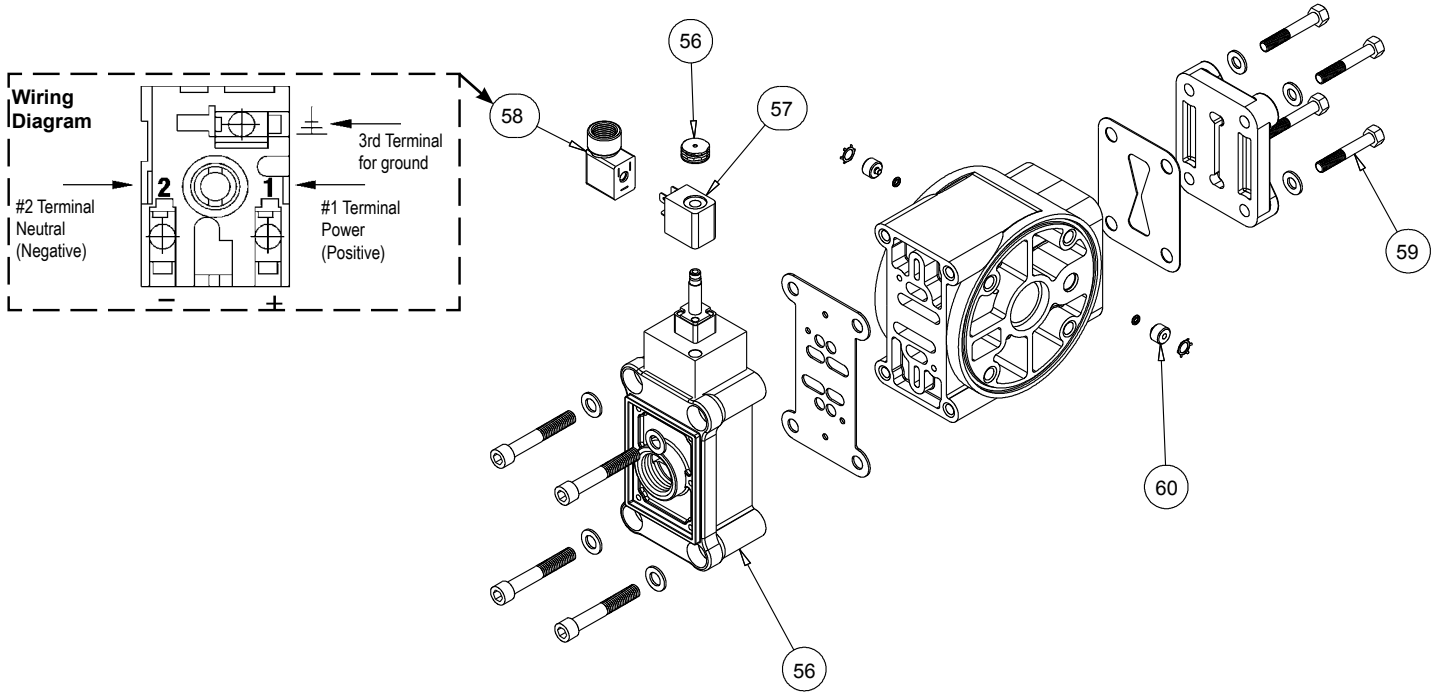

Solenoid Shifted Air Valve Parts List

(Includes All Items Used on Composite Repair Parts List Except as Shown)

| Item | Part Number | Description | Qty |
|------|-------------|-----------------------------------|-----|
| 56 | 893-097-000 | Solenoid Valve, NEMA4 | 1 |
| 57 | 219-001-000 | Solenoid Coil, 24VDC | 1 |
| | 219-004-000 | Solenoid Coil, 24VAC/12VDC | 1 |
| | 219-002-000 | Solenoid Coil, 120VAC | 1 |
| | 219-003-000 | Solenoid Coil, 240VAC | 1 |
| 58 | 241-001-000 | Connector, conduit | 1 |
| 59 | 170-029-330 | Capscrew, Hex HD 5/16 - 18 x 1.50 | 4 |
| 60 | 618-051-150 | Plug | 2 |



IEC EEx m T4



For Explosion Proof Solenoid Coils used in North America and outside the European Union.

| | | | |
|----|-------------|-----------------------------|---|
| 57 | 219-009-001 | Solenoid Coil, 120VAC 60 Hz | 1 |
| | 219-009-002 | Solenoid Coil, 240VAC 60 HZ | 1 |
| | 219-009-003 | Solenoid Coil, 12VDC | 1 |
| | 219-009-004 | Solenoid Coil, 24VDC | 1 |
| | 219-009-005 | Solenoid Coil, 110VAC 50 Hz | 1 |
| | 219-009-006 | Solenoid Coil, 230VAC 50 Hz | 1 |

Note: Item 58 (Conduit Connector) is not required



II 2G EEx m c II T5
II 3/2 G Ex m c II T5
II 2D c IP65 T100°C

*** For ATEX Compliant Solenoid Coils used in the European Union**

| | | | |
|----|-------------|--|---|
| 57 | 219-011-001 | Solenoid Coil, Single mounting 12 VDC, 3.3W / 267mA | 1 |
| | 219-011-002 | Solenoid Coil, Single mounting 24 VDC, 3.3W / 136mA | 1 |
| | 219-011-003 | Solenoid Coil, Single mounting 110/120 VAC, 3.4W / 29mA | 1 |
| | 219-011-004 | Solenoid Coil, Single mounting 220/240 VAC, 3.4W / 15mA | 1 |

Note: Item 37 (Conduit Connector) is not required

Compressed Air Temperature Range: Maximum Ambient Temperature to plus 50°C

Solenoid Shifted Operation

The Solenoid Shifted SANDPIPER has a solenoid operated, air distribution valve in place of the standard SANDPIPER's pilot operated, air distribution valve. Where a pilot valve is normally utilized to cycle the pump's air distribution valve, an electric solenoid is utilized. As the solenoid is powered, one of the pump's air chambers is pressurized while the other chamber is exhausted. When electric power is turned off, the solenoid shifts and the pressurized chamber is exhausted while the other chamber is pressurized. By alternately applying and removing power to the solenoid, the pump cycles much like a standard SANDPIPER pump, with one exception. This option provides a way to precisely control and monitor pump speed.

Before Installation

Before wiring the solenoid, make certain it is compatible with your system voltage.

*Special Conditions For Safe Use

A fuse corresponding to its rated current (max. $3 \cdot I_{rat}$ according IEC 60127-2-1) or a motor protecting switch with short-circuit and thermal instantaneous tripping (set to rated current) shall be connected in series to each solenoid as short circuit protection. For very low rated currents of the solenoid the fuse of lowest current value according to the indicated IEC standard will be sufficient. The fuse may be accommodated in the associated supply unit or shall be separately arranged. The rated voltage to the fuse shall be equal to or greater than the stated rated voltage of the magnet coil. The breakage capacity of the fuse-link shall be as high as or higher than the maximum expected short circuit current at the location of the installation (usually 1500 A). A maximum permissible ripple of 20% is valid for all magnets of direct-current design.

Dual Port Option

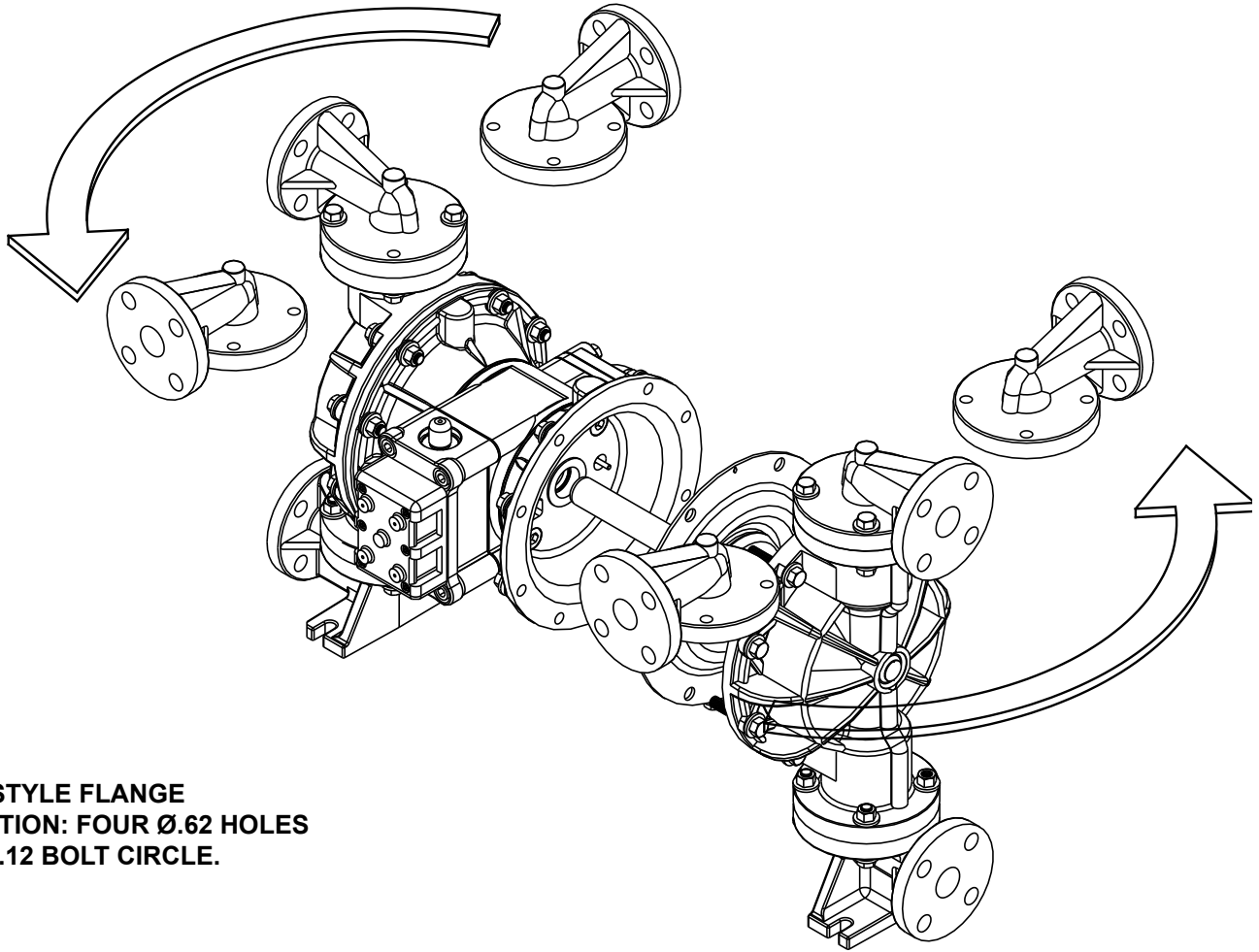

1" ANSI STYLE FLANGE CONNECTION: FOUR Ø.62 HOLES ON A Ø 3.12 BOLT CIRCLE.

DUAL PORTING OPTIONS

Several dual porting options are possible. The pump can be converted to a dual port arrangement on both the suction and the discharge ends. The porting can be configured to a single suction and a dual discharge. The porting can be changed to a dual suction and a single discharge.

The above changes are possible because the porting flange of the elbows (items 18 and 19) are designed to mate with standard 125# ANSI style 4-bolt, 1" pipe flanges.

DUAL PORTING OF BOTH SUCTION AND DISCHARGE ENDS OF THE PUMP

Converting the pump from the standard single suction and discharge porting configuration to dual porting at each end is easy. Simply remove the manifold seals, spacers, and manifolds (items 35 and 23 from pump assembly drawing) from the pump.

The discharge and suction elbows can be rotated at 90° increments (see arrows and optional positioning in the Dual Porting Drawing).

SINGLE PORTING OF THE SUCTION AND DUAL PORTING OF THE PUMP DISCHARGE

To convert the pump from the standard single suction and single discharge porting configuration to a dual discharge porting arrangement remove the only the discharge manifolds, spacers, and manifold seals. Position the discharge elbows in the desired direction at 90° increments. (See arrows and optional positioning in the Dual Porting Drawing.)

DUAL PORTING OF THE SUCTION AND SINGLE PORTING OF THE PUMP DISCHARGE

To convert the pump from the standard single suction and single discharge porting configuration to a dual suction porting arrangement remove the only the suction (bottom) manifolds, spacers, and manifold seals.

Position the suction elbows in the desired direction at 90° increments. (See arrows and optional positioning in the Dual Porting Drawing.)

Leak Detection Options Drawing

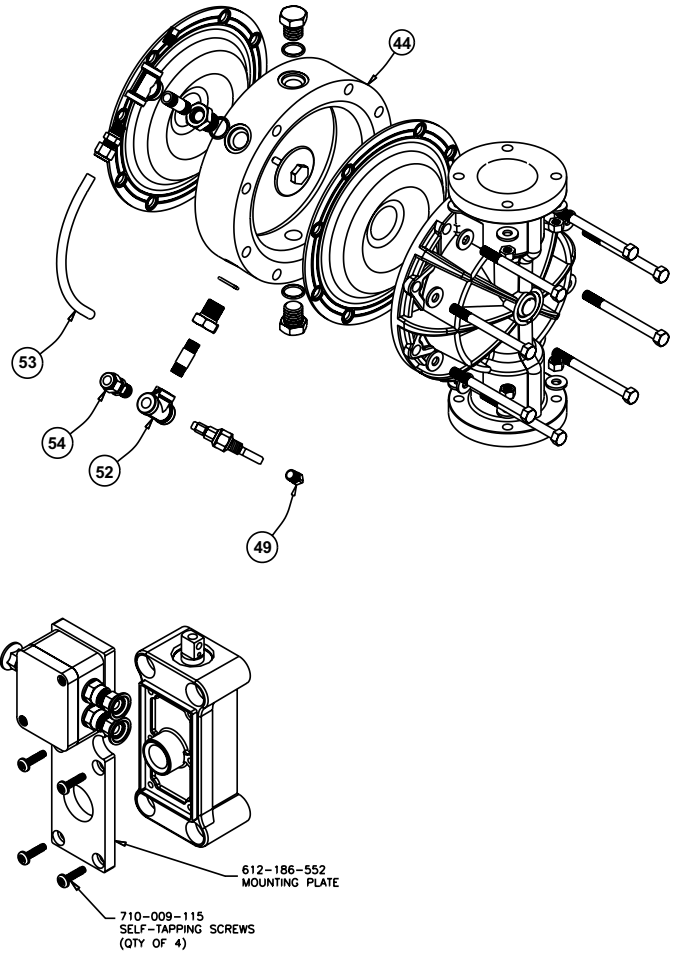
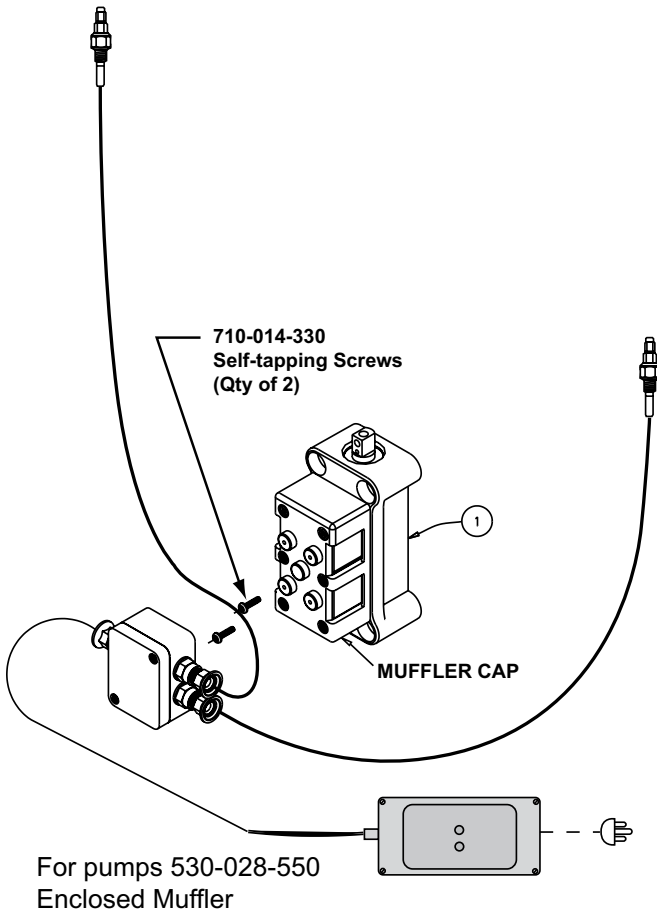

For pumps with Alternate Mufflers

LEAK DETECTION OPTION A (ELECTRONIC)

Follow instructions found elsewhere in this manual, "Filling the Spill Containment Chambers" when installing leak detectors.

Electronic Leak Detector Installation

| | | |
|-----------------|---------------|-----------|
| Kit 032-037-000 | 100VAC | 50Hz |
| | or 110-120VAC | 50 / 60Hz |
| | or 220-240VAC | 50 / 60Hz |
| Kit 032-045-000 | 12-32VDC | |

To install electronic leak detectors, remove the bottom 1/4" NPT pipe plug on the visual sight tube (item 53). Insert leak detector into the 1/4" pipe tee (item 52).

Leak Detection Option B (Mechanical)

Follow instructions found elsewhere in this manual, "Filling the Spill Containment Chambers" when installing leak detectors.

Mechanical Leak Detector Installation

Kit 031-023-110

To install mechanical leak detectors, remove the bottom 1/4" NPT pipe plug on the visual sight tube (item 53). Insert leak detector into the 1/4" pipe tee (item 52).

Written Warranty

5 - YEAR Limited Product Warranty

Quality System ISO 9001 Certified • Environmental Management Systems ISO 14001 Certified

Warren Rupp, Inc. ("Warren Rupp") warrants to the original end-use purchaser that no product sold by Warren Rupp that bears a Warren Rupp brand shall fail under normal use and service due to a defect in material or workmanship within five years from the date of shipment from Warren Rupp's factory. Warren Rupp brands include SANDPIPER®, MARATHON®, PortaPump®, SludgeMaster™ and Tranquilizer®.

~ See complete warranty at sandpiperpump.com/content/warranty-certifications ~

**WARREN
RUPP, INC.®**

Declaration of Conformity

Manufacturer: Warren Rupp, Inc.®, 800 N. Main Street
Mansfield, Ohio, 44902 USA

Certifies that Air-Operated Double Diaphragm Pump Series: HDB, HDF, M Non-Metallic, S Non-Metallic, M Metallic, S Metallic, T Series, G Series, U Series, EH and SH High Pressure, RS Series, W Series, SMA and SPA Submersibles, and Tranquilizer Surge Suppressors comply with the European Community Directive 2006/42/EC on Machinery, according to Annex VIII. This product has used Harmonized Standard EN809:1998+A1:2009, Pumps and Pump Units for Liquids - Common Safety Requirements, to verify conformance.

David Roseberry
Signature of authorized person

David Roseberry
Printed name of authorized person

Revision Level: F

October 20, 2005
Date of issue

Engineering Manager
Title

August 23, 2012
Date of revision

IDEX
FLUID & METERING



WARREN RUPP, INC.®

EC Declaration of Conformity

In accordance with ATEX Directive 94/9/EC,
Equipment intended for use in potentially explosive environments.

Manufacturer: Warren Rupp, Inc.®, A Unit of IDEX Corporation
800 North Main Street, P.O. Box 1568, Mansfield, OH 44902 USA

EN 60079-25: 2011

For pumps equipped with Pulse Output ATEX Option
Quality B.V. (0344)

Applicable Standard:
EN13463-1: 2009
EN13463-5: 2011



AODD Pumps and Surge Suppressors

For Type Examination Designations

AODD (Air-Operated Double Diaphragm) Pumps

EC Type Examination Certificate No. Pumps: KEMA 09ATEX0071 X
DEKRA Certification B.V. (0344)
Meander 1051
6825 MJ Arnhem
The Netherlands



Tranquilizer®



DATE/APPROVAL/TITLE:
14 MAY 2014

David Roseberry
David Roseberry, Engineering Manager

ATEX Summary of Markings

| Type | Marking | Listed In | Non-Conductive Fluids | |
|--|--|---|---|-------------------------------|
| Pump types, S1F, S15, S20, and S30 provided with the pulse output option | II 2 G Ex ia c IIC T5 II 3/2 G Ex ia c IIC T5 II 2 D Ex c iaD 20 IP67 T100°C | KEMA 09ATEX0071 X CE 0344 | KEMA 09ATEX0071 X KEMA 09ATEX0071 X KEMA 09ATEX0071 X | No Yes Yes |
| Pump types, S1F, S15, S20, and S30 provided with the integral solenoid option | II 2 G EEx m c II T5 II 3/2 G EEx m c II T5 II 2 D c IP65 T100°C | KEMA 09ATEX0071 X CE 0344 | KEMA 09ATEX0071 X KEMA 09ATEX0071 X KEMA 09ATEX0071 X | No Yes Yes |
| Pump types, HDB1½, HDB40, HDB2, HDB50, HDB3, HDF1, HDF25, HDF2, HDF3M, PB¼, S05, S1F, S15, S20, S30, SB1, SB25, ST1½, ST40, G15, G20, and G30, without the above listed options, no aluminum parts | II 1 G c T5 II 3/1 G c T5 II 1 D c T100°C I M1 c I M2 c | KEMA 09ATEX0071 X KEMA 09ATEX0072 X CE 0344 | KEMA 09ATEX0071 X KEMA 09ATEX0071 X KEMA 09ATEX0071 X KEMA 09ATEX0071 X KEMA 09ATEX0072 X | No Yes Yes No Yes |
| Pump types, DMF2, DMF3, HDB1½, HDB40, HDB2, HDB50, HDB3, HDF1, HDF25, HDF2, HDF3M, PB¼, S05, S1F, S15, S20, S30, SB1, SB25, SE½, ST1, ST25, ST1½, ST40, U1F, G05, G1F, G15, G20, and G30 | II 2 G c T5 II 3/2 G c T5 II 2 D c T100°C | KEMA 09ATEX0072 X CE | KEMA 09ATEX0072 X KEMA 09ATEX0072 X KEMA 09ATEX0072 X | No Yes Yes |
| Surge Suppressors all types | II 2 G T5 II 3/2 G T5 II 2 D T100°C | KEMA 09ATEX0073 CE | KEMA 09ATEX0073 KEMA 09ATEX0073 KEMA 09ATEX0073 | No Yes Yes |

EC Type Certificate No. Pumps: KEMA 09ATEX0071 X
Type Certificate No. Pumps: KEMA 09ATEX0072 X
Type Certificate No. Suppressors: KEMA 09ATEX0073